

RICAMBI - SPARE PARTS - PIECES DETACHEES

LAVABICCHIERI

GLASSWASHERS

LAVE VERRES

UNO CS - UNO CL - DUE CS - DUE CL

JA40 - JA41 - JA400 - JA410



LAVASTOVIGLIE - DISHWASHERS - LAVE VAISSELLE - GESCHIRRSPUELER - LAVAPLATOS

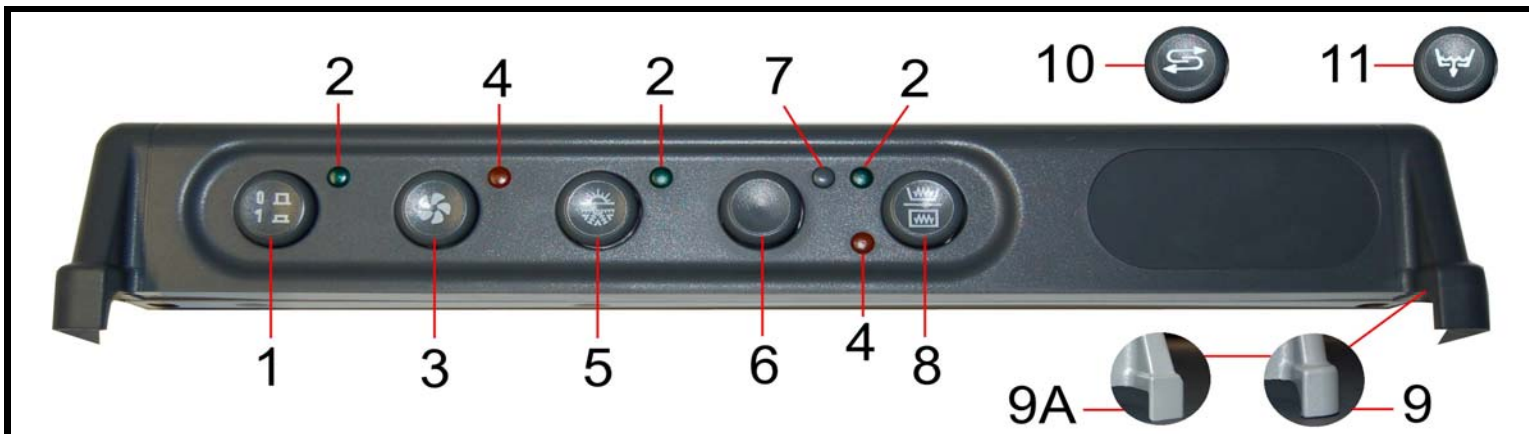

Pos.	Codice	Descrizione	Description	Description
1	CETP25G01	Tasto tondo grigio "0-1"	On/off button, round, grey	Bouton "0-1", rond gris
2	CEGV6	Gemma verde 6mm	Lens, green, 6mm	Voyant vert, 6mm
3	CETP25GPC	Tasto tondo grigio "partenza ciclo"	Cycle start button, round, grey	Bouton "Départ cycle", rond, gris
4	CEGA6	Gemma arancio 6mm	Lens, orange, 6mm	Voyant orange, 6mm
5	CETP25GRF	Tasto tondo grigio "risciacquo freddo"	Cold rinse button, round, grey	Bouton "Rinçage froid", rond, gris
6	CETP25GR	Tasto tondo grigio "tappo"	Button, round, grey	Bouton "Bouchon", rond, gris
7	CETP6GR	Tappo spia grigio 6mm	Cap, warning light, grey	Bouchon gris, 6mm
8	CETP25GRRS	Tasto tondo grigio "resistenze"	Heater indicator button, round, grey	Bouton "Résistances", rond, gris
9	CEPC1D25RGR	Pannello comandi vasca raggiata	Control panel, plastic, grey	Panneau de contrôle, plastique, gris
9A	CEPC1D25QGR	Pannello comandi vasca quadra	Control panel, plastic, grey	Panneau de contrôle, plastique, gris
10	CETP25GRR	Tasto tondo grigio "rigenerazione"	Regeneration button, round, orange	Bouton "Régénération", rond, gris
11	CETP25GPS	Tasto tondo grigio "pompa scarico"	Drain pump button, round, grey	Bouton "Pompe de vidange", rond, gris

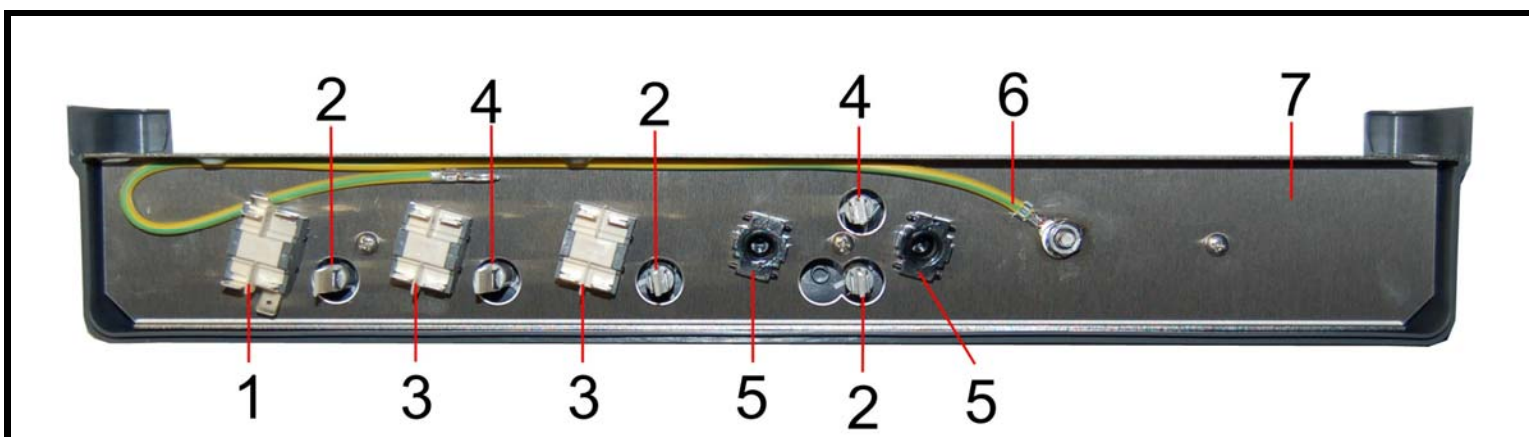

Pos.	Codice	Descrizione	Description	Designiation
1	CEDPPFD	Deviatore bipolare	Inner switch, latched	Deviateur bipolaire
2	CESPV6	Lampada verde 6mm	Lamp assy, 6mm, green	Ampoule verte, 6mm
3	CEPBPF	Pulsante bipolare	Inner push button momentary	Bouton bipolaire
4	CESPA6	Lampada arancio 6mm	Lamp assy, 6mm, orange	Ampoule orange, 6mm
5	CETP25SF	Supporto tasto fisso	Support for indicator button	Support bouton fixe
6	CECBCTB2	Catenaria circuito terra	Earth grounding wire	Cable de circuit à la terre
7	GMPI1D25RDP	Portainterruttori inox	Steel inner control panel	Porte-interrupteur inox

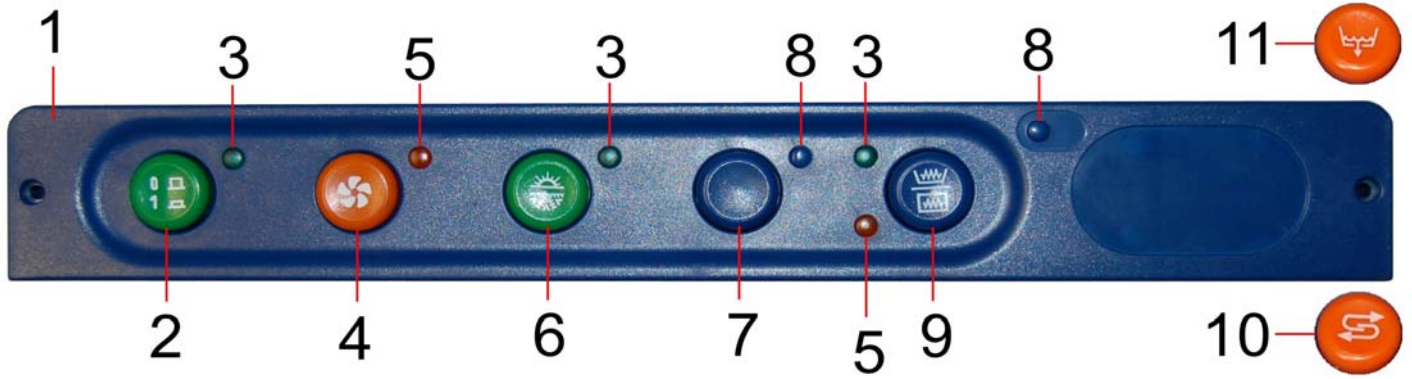

Pos.	Codice	Descrizione	Description	Description
1	CEPC1D25	Pannello comandi blu	Control panel, plastic, blue	Panneau de commande
2	CETP25V01	Tasto tondo verde "0-1"	On/off button, round, green	Bouton "0-1", rond, vert
3	CEGV6	Gemma verde, 6mm	Lens, green, 6mm	Voyant vert, 6mm
4	CETP25APC	Tasto tondo arancio "partenza ciclo"	Cycle start button, round, orange	Bouton "Depart cycle", rond, orange
5	CEGA6	Gemma arancio dm. 6mm	Lens, orange, 6mm	Voyant orange, 6mm
6	CETP25VRF	Tasto tondo verde "risciacquo freddo"	Cold rinse button, round, green	Bouton "Rinçage froid", rond, vert
7	CETP25B	Tasto tondo blu "tappo"	Button, round, blue	Bouton "Bouchon", rond, bleu
8	CETP6B	Tappo foro spia blu, 6mm	Cap, warning light, blue, 6mm	Bouchon bleu, 6mm
9	CETP25BR	Tasto tondo blu "resistenze"	Heater indicator button, round, blue	Bouton "Résistance", rond, bleu
10	CETP25AR	Tasto tondo arancio "rigenerazione"	Re-set button, round, orange	Bouton "Régénération", rond, orange
11	CETP25APS	Tasto tondo arancio "pompa scarico"	Drain button, round, orange	Bouton "Pompe de vidange", orange

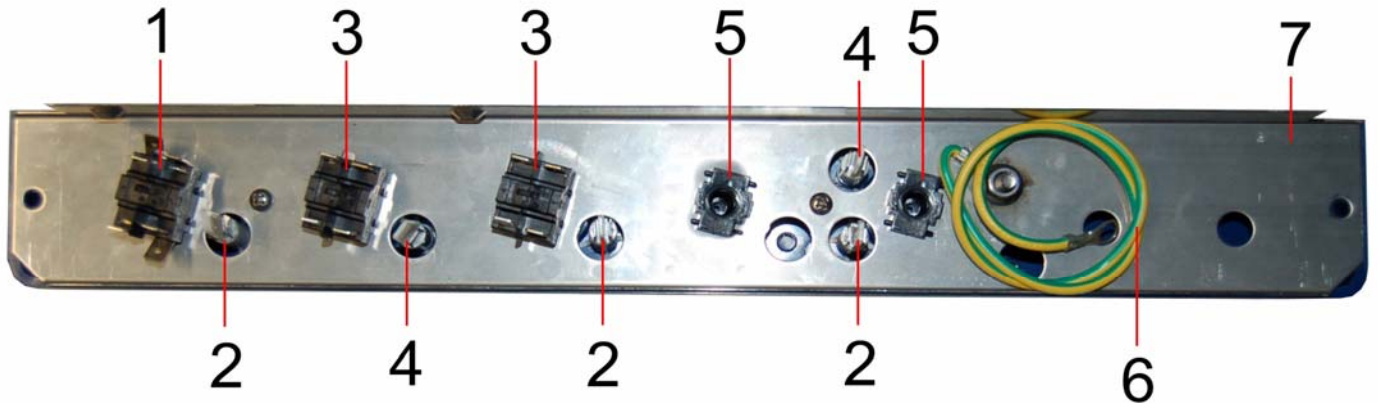

Pos.	Codice	Descrizione	Description	Description
1	CEDPPFD	Deviatore bipolare	Inner switch, latched	Deviateur bipolaire
2	CESPV6	Lampada verde, 6mm	Lamp assy, 6mm, green	Ampoule vert, 6mm
3	CEPBPF	Pulsante bipolare	Inner push button momentary	Bouton bipolaire
4	CESPA6	Lampada arancio, 6mm	Lamp assy, 6mm, orange	Ampoule orange, 6mm
5	CETP25SF	Supporto tasto fisso	Support for indicator button	Support bouton fixe
6	CECBCTB2	Catenaria circuito terra	Earth grounding wire	Cable de circuit à la terre
7	GMPI1NOS	Portainterruttori inox	Steel control panel	Porte-interrupteur inox

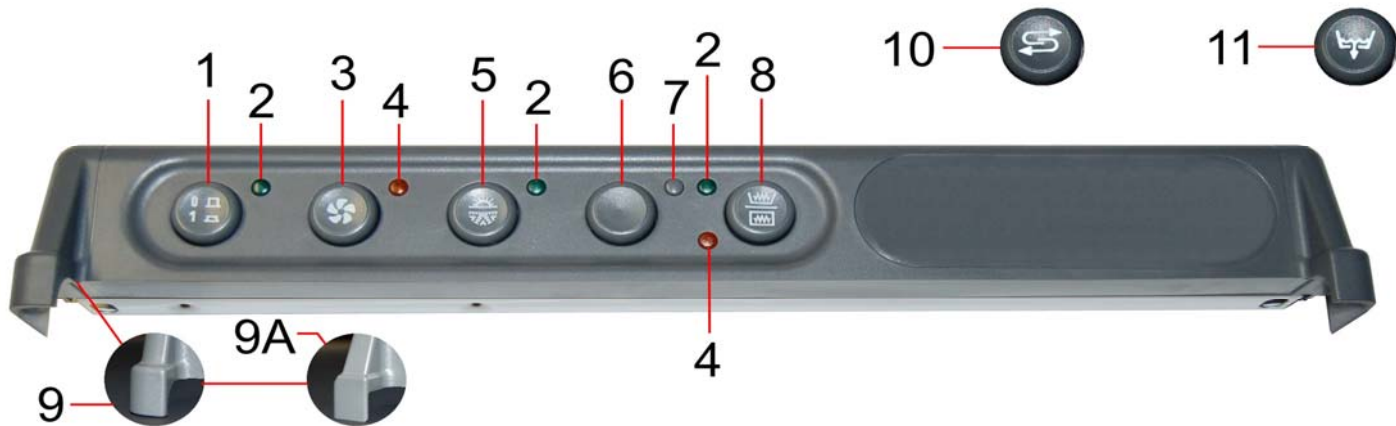

Pos.	Codice	Descrizione	Description	Description
1	CETP25G01	Tasto tondo grigio "0-1"	On/off button, round, grey	Bouton rond gris "0-1"
2	CEGV6	Gemma verde 6mm	Lens, green, 6mm	Voyant vert, 6mm
3	CETP25GPC	Tasto tondo grigio "partenza ciclo"	Cycle start button, round, grey	Bouton rond gris "départ cycle"
4	CEGA6	Gemma arancio 6mm	Lens, orange, 6mm	Voyant orange, 6mm
5	CETP25GRF	Tasto tondo grigio "risciacquo freddo"	Cold rinse button, round, grey	Bouton rond gris "rinçage froid"
6	CETP25GR	Tasto tondo grigio "tappo"	Button, round, grey (cap)	Bouton rond gris "Bouchon"
7	CETP6GR	Tappo spia grigio 6mm	Cap, warning light, grey	Bouchon gris, 6mm
8	CETP25GRRS	Tasto tondo grigio "resistenze"	Heater indicator button, round, grey	Bouton rond gris "résistances"
9	CEPC2D25RGR	Pannello comandi vasca raggiata	Control panel, plastic, grey	Panneau de contrôle, plastic, gris
9A	CEPC2D25QGR	Pannello comandi vasca quadra	Control panel, plastic, grey	Panneau de contrôle, plastic, gris
10	CETP25GRR	Tasto tondo grigio "rigenerazione"	Regeneration button, round, grey	Bouton rond gris "régénération"
11	CETP25GPS	Tasto tondo grigio "pompa scarico"	Drain pump button, round, grey	Bouton rond gris "pompe de vidange"

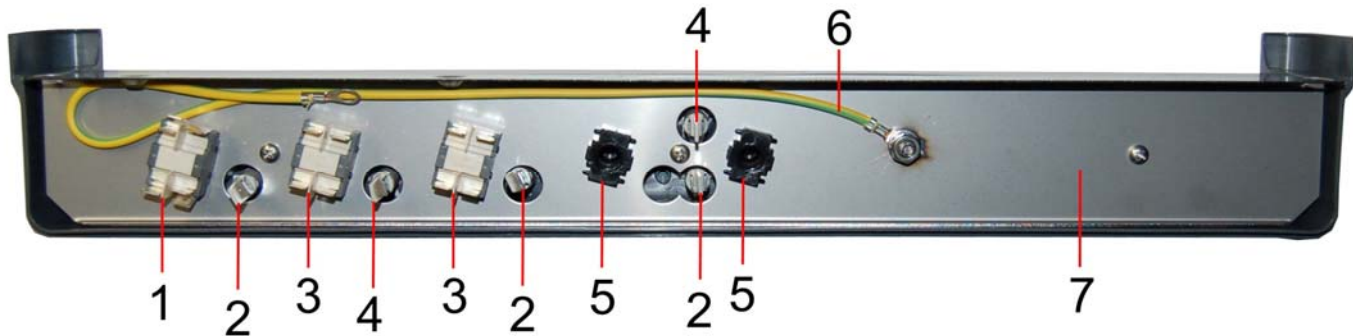

Pos.	Codice	Descrizione	Description	Description
1	CEDPPFD	Deviatore bipolare	Inner switch, latched	Selecteur bipolaire
2	CESPV6	Lampada verde 6mm	Lamp assy, green, 6mm	Ampoule verte, 6mm
3	CEBPFD	Pulsante bipolare	Inner push button momentary	Bouton bipolaire
4	CESPA6	Lampada arancio 6mm	Lamp assy, orange, 6mm	Ampoule orange, 6mm
5	CETP25SF	Supporto tasto fisso	Support for button	Support bouton fix
6	CECBCTB2	Catenaria circuito terra	Earth grounding wire	Cable de circuit à la terre
7	GMPI2D25SFRDP	Portainterruttori inox	Steel inner control panel	Porte-interrupteur inox

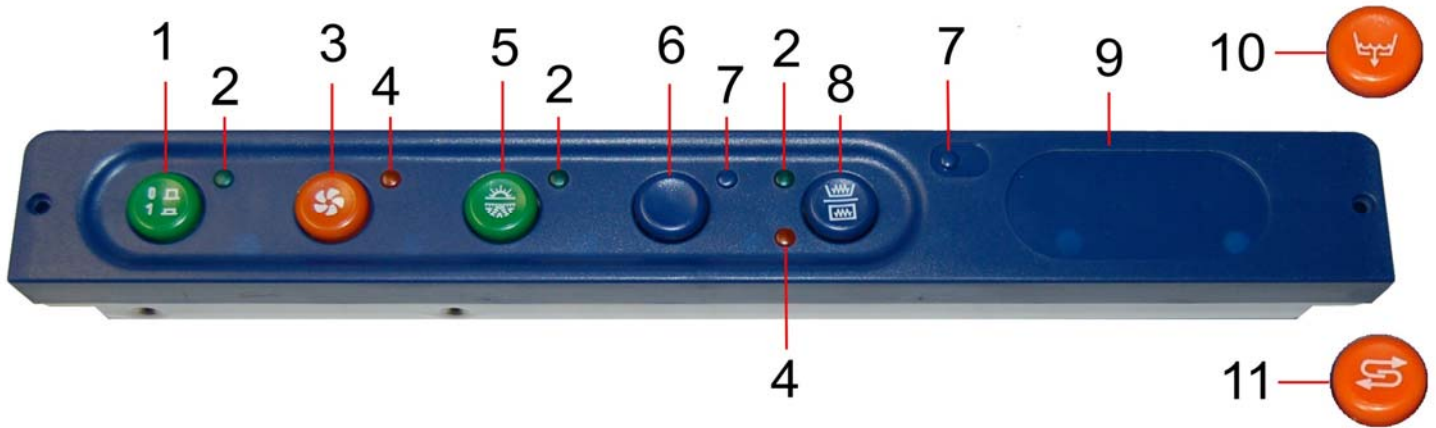

Pos.	Codice	Descrizione	Description	Description
1	CETP25V01	Tasto tondo verde "0-1"	On/off button, round, green	Bouton rond vert "0/1"
2	CEGV6	Gemma verde 6mm	Lens, green, 6mm	Voyant vert, 6mm
3	CETP25APC	Tasto tondo arancio "partenza ciclo"	Cycle start button, round, orange	Bouton rond orange depart cycle
4	CEGA6	Gemma arancio 6mm	Lens, orange, 6mm	Voyant orange, 6mm
5	CETP25VRF	Tasto tondo verde "risciacquo freddo"	Cold rinse button, round, green	Bouton rond vert rinçage froid
6	CETP25B	Tasto tondo blu "tappo"	Button, round, blue (cap)	Bouton rond bleu "Bouchon"
7	CETP6B	Tappo foro spia blu dm. 6mm	Cap, warning light, blue, dm. 6mm	Bouchon bleu, dm. 6mm
8	CETP25BR	Tasto tondo blu "resistenze"	Heater indicator button, round, blue	Bouton rond bleu résistance
9	CEPC2D25	Pannello comandi blu	Control panel, plastic, blue	Panneau de controle
10	CETP25APS	Tasto tondo arancio "pompa scarico"	Drain button, round, orange	Bouton orange pompe de vidange
11	CETP25AR	Tasto tondo arancio "rigenerazione"	Regeneration button, round, orange	Bouton rond orange régénération

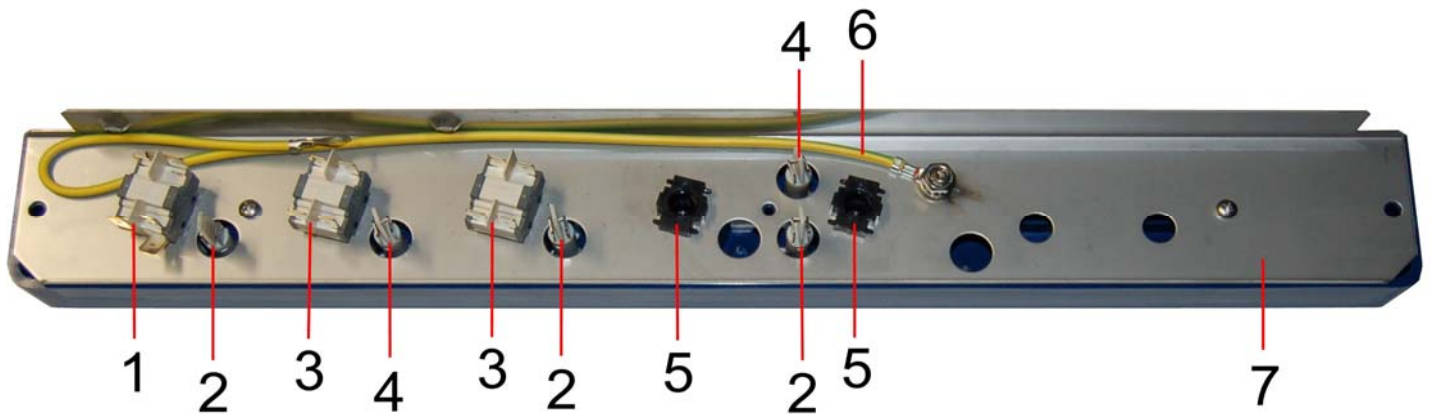

Pos.	Codice	Descrizione	Description	Designation
1	CEDPPFD	Deviatore bipolare	Inner switch, latched	Deviateur bipolaire
2	CESPV6	Lampada verde 6mm	Lamp assy, green, 6mm	Ampoule vert, 6mm
3	CEBPFD	Pulsante bipolare	Inner push button momentary	Bouton bipolaire
4	CESPA6	Lampada arancio 6mm	Lamp assy, orange, 6mm	Ampoule orange, 6mm
5	CETP25SF	Supporto tasto fisso	Support for button	Support bouton fix
6	CECBCTB2	Catenaria circuito terra	Earth grounding wire	Cable de circuit à la terre
7	GMPI2NOS	Portainterruttori inox	Steel inner control panel	Porte-interrupteur inox

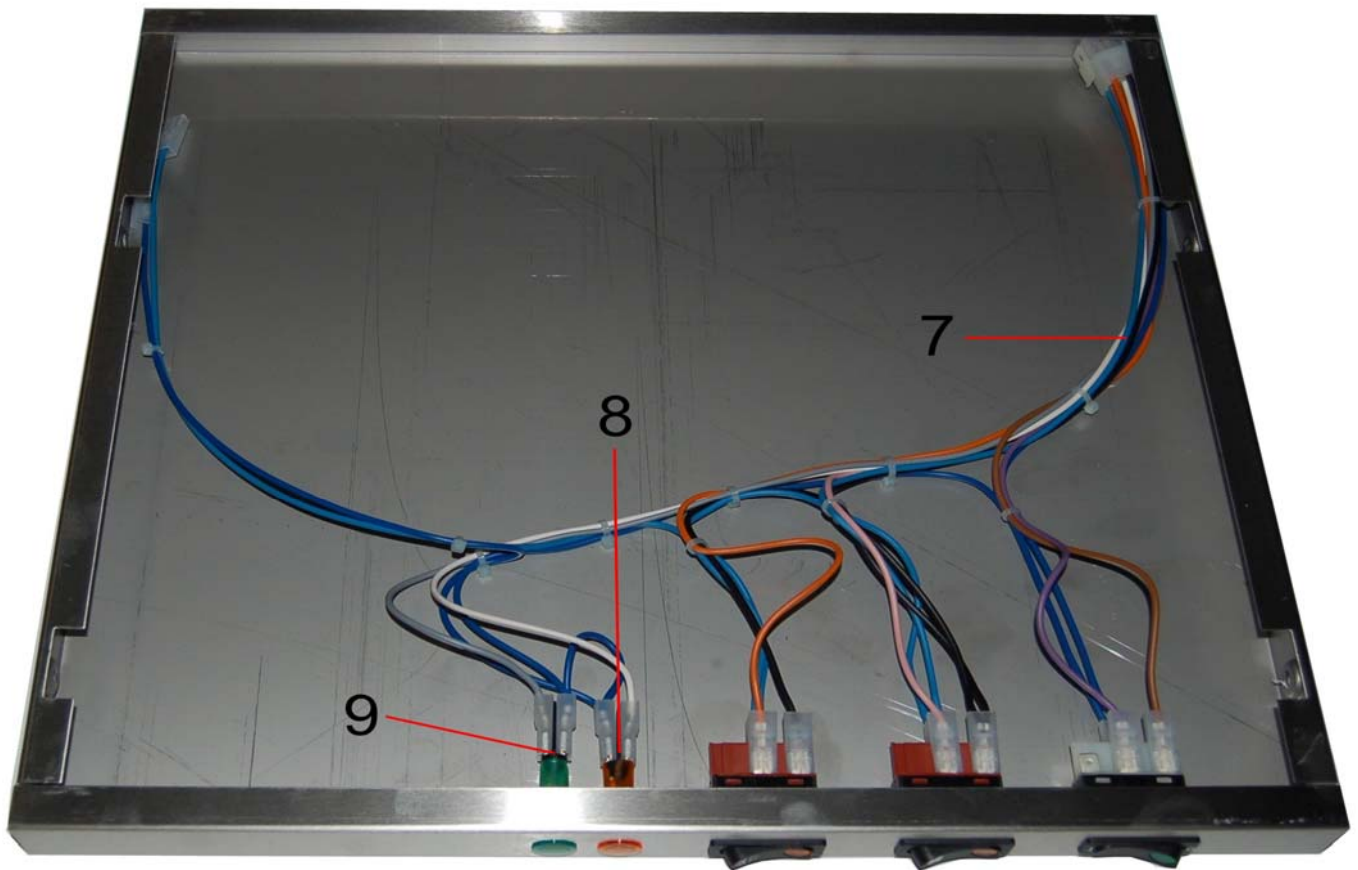
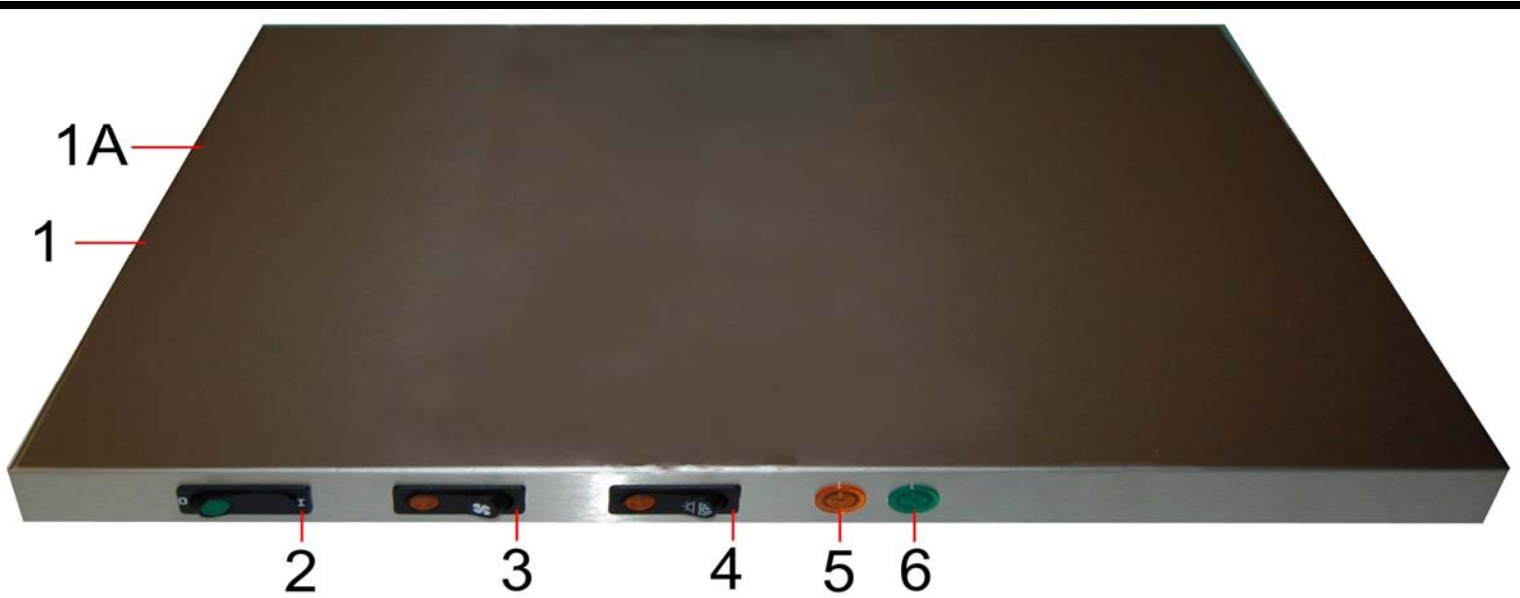

Pos.	Codice	Descrizione	Description	Description
1	GMPS1CSN	Pannello superiore inox mod 1	Top panel, steel, mod.1	Panneau supérieur, mod. 1
1A	GMPS2CSN	Pannello superiore inox mod 2	Top panel, steel, mod. 2	Panneau supérieur, mod. 2
2	CEIN3012	Interruttore 0-1	ON-OFF switch	Interrupteur ON-OFF
3	CEPUC3012	Pulsante ciclo	Cycle start switch	Bouton départ cycle
4	CEPUR3012	Pulsante risciacquo freddo	Rinse switch	Bouton rinçage froid
5	CESPE32	Gemma arancio	Cover, orange	Voyant, jaune
6	CESPE31	Gemma verde	Cover, green	Voyant, vert
7	CECBSPCCS	Cablaggio superiore	Upper loom	Cable supérieur
8	CESP27	Spia arancio	Warning light, orange	Ampoule voyant, orange
9	CESP27V	Spia verde	Warning light, green	Ampoule voyant, verte

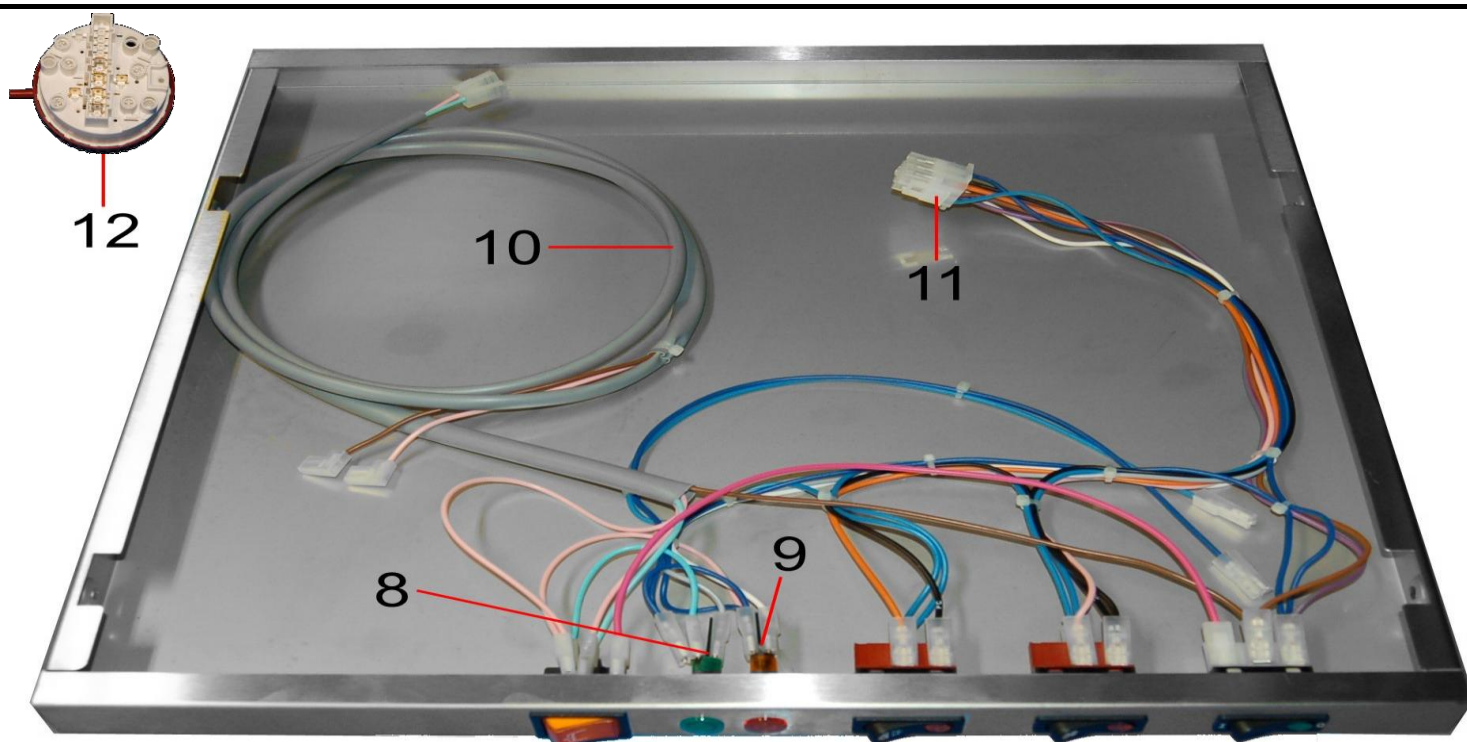

Pos.	Codice	Descrizione	Description	Description
1	CEIN3012	Interruttore 0-1	ON-OFF switch	Interrupteur ON-OFF
2	CEPUC3012	Pulsante ciclo	Cycle start switch	Bouton depart cycle
3	CEPUR3012	Pulsante risciacquo freddo	Rinse switch	Bouton rinçage froid
4	CESPE32	Gemma arancio	Cover, orange	Voyant, orange
5	CESPE31	Gemma verde	Cover, green	Voyant, vert
6	CEPUPS	Drain switch, orange	Button, drain pump	Bouton orange, pompe de vidange
7	GMPS2CSNLPS	Pannello superiore inox	Top panel, steel	Panneau supérieur, inox
8	CESP27V	Spia verde	Warning light, green	Ampoule voyant, verte
9	CESP27	Spia arancio	Warning light, orange	Ampoule voyant, orange
10	CECBPS12	Cablaggio pompa scarico	Loom, drain pump	Cable, pompe de vidange
11	CECBSPCCS	Cablaggio superiore	Upper loom	Cable supérieur
12	CEPRE2LUL	Pressostato 2 livelli	Double air pressure switch	Pressostat, 2 niveaux

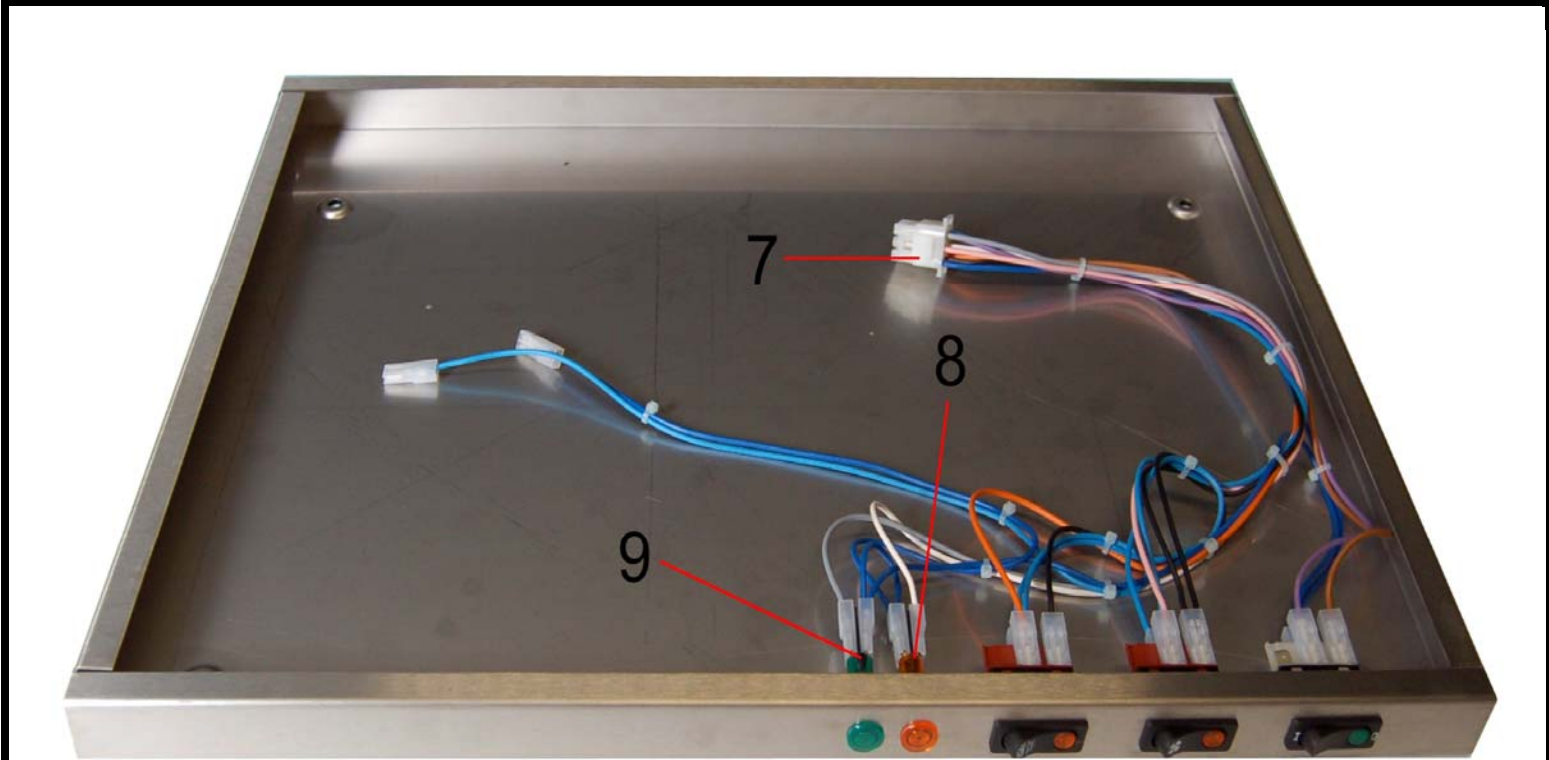
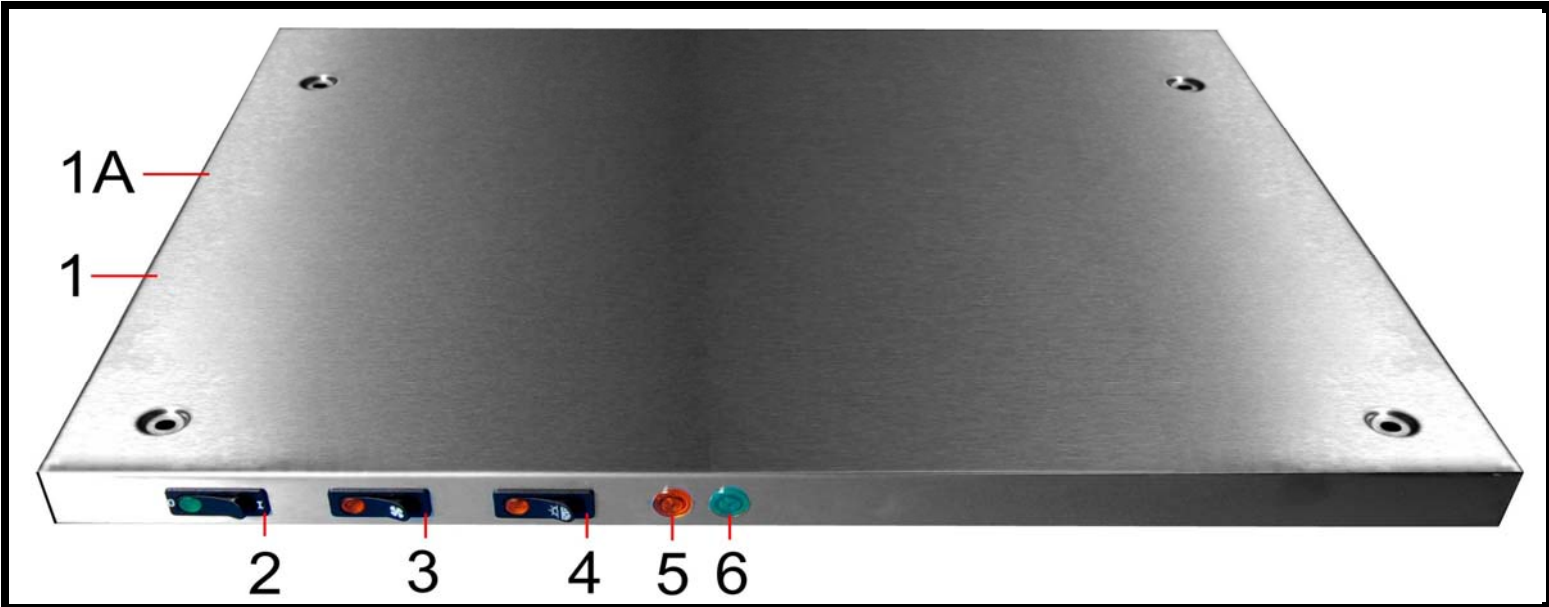

Pos.	Codice	Descrizione	Description	Description
1	GMPL1CLNT	Pannello laterale mod. 35x35	Side panel, mod. 35x35	Panneau latéral, mod. 35x35
1A	GMPL2ACLNT	Pannello laterale mod. 40x40	Side panel, mod. 40x40	Panneau latéral, mod. 40x40
2	CEIN3012	Interruttore 0-1	ON-OFF switch	Interrupteur ON-OFF
3	CEPUC3012	Pulsante ciclo	Cycle start switch	Bouton depart cycle
4	CEPUR3012	Pulsante risciacquo freddo	Rinse switch	Bouton rinçage froid
5	CESPE32	Gemma arancio	Cover, orange	Voyant, jaune
6	CESPE31	Gemma verde	Cover, green	Voyant, vert
7	CECBSPCCS	Cablaggio superiore	Upper loom	Cable supérieur
8	CESP27	Spia arancio	Warning light, orange	Ampoule voyant, orange
9	CESP27V	Spia verde	Warning light, green	Ampoule voyant, verte

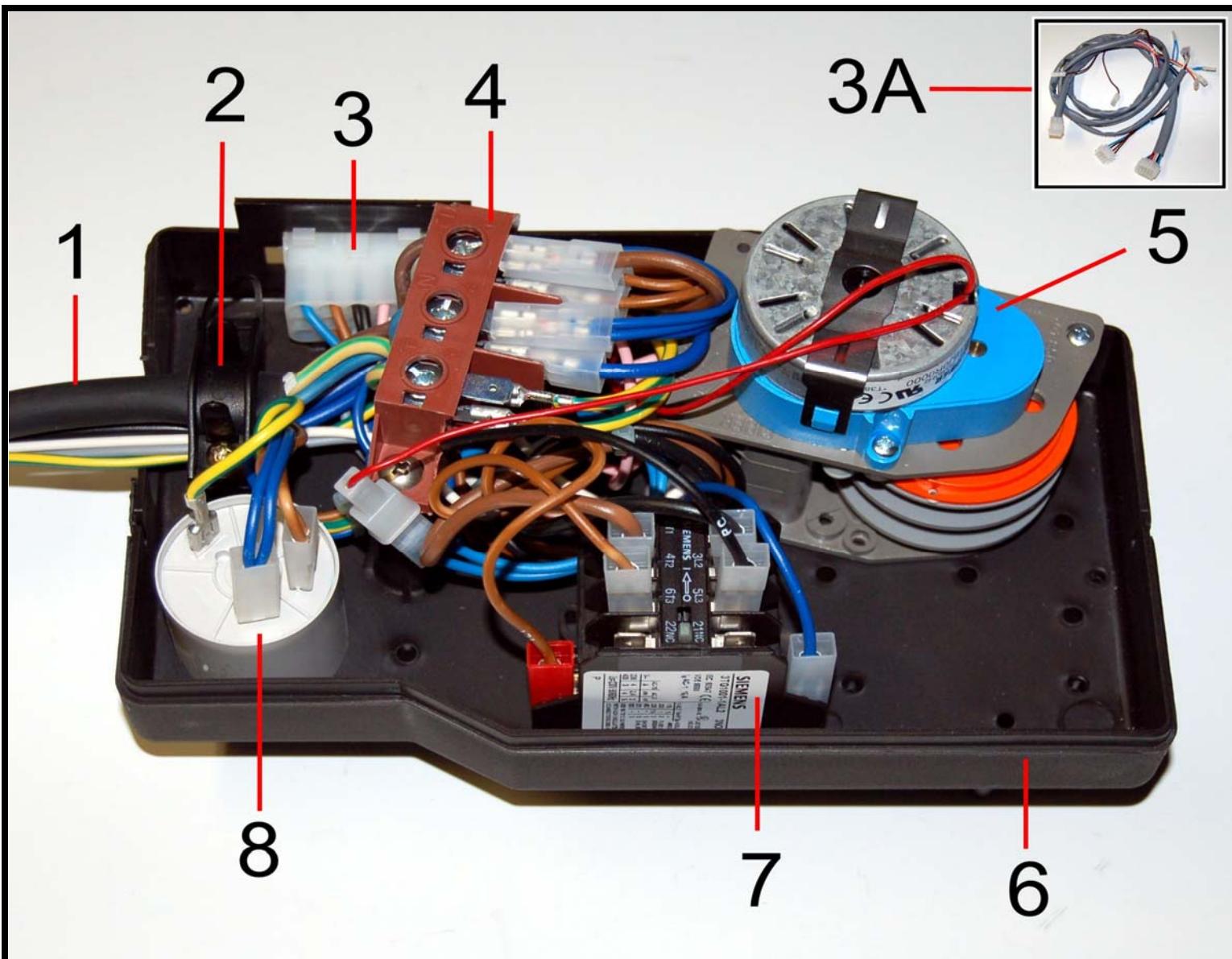

Pos.	Codice	Descrizione	Description	Description
1	CECE25	Cavo alimentazione	Electric supply cable	Cable d'alimentation
2	CEFI6	Fissacavo interno con viti	O ring 122	Arret de cable intérieur
3	CECBICSLNT	Cablaggio inferiore	Lower loom	Cablage inférieur
3A	CECBSCSLNT	Cablaggio superiore	Upper loom	Cablage supérieur
4	CEM0S	Morsettiera	3-way terminal block	Bornier
5	CETF12	Timer ciclo	Cycle timer, 2 mins	Programmateur cycle fix
6	CEPCEBCSL	Base scatola cablaggio	Door plunger body	Boite cablage
7	CECTF	Teleruttore	4-p contactor	Contacteur
8	CEFA	Filtro antidisturbo	Electric supply cable	Filtre électrique
9	CEPCECCSL	Coperchio scatola cablaggio	Electric component box lid	Couvercle boite cablage
10	CECBSCSLNTCC	Scatola cablaggio completa assemblata	Electrical component assembly	Boite cablage complète

Solo per comandi laterali



For appliances with side controls only

Seulement pour appareils avec commandes latéraux

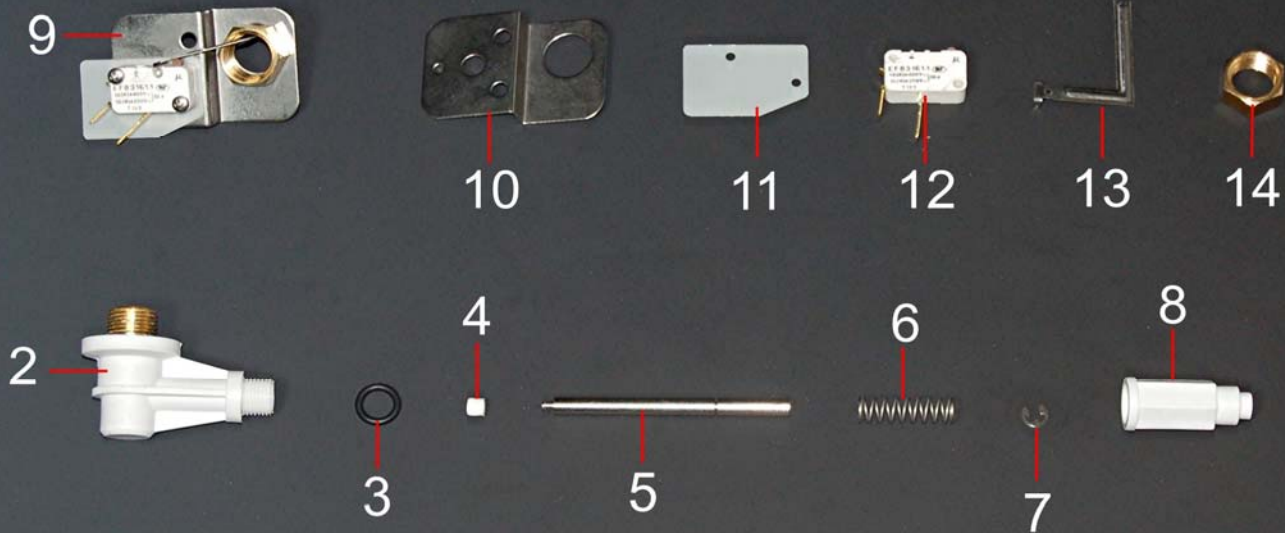

Per tutti i modelli

For all models

Pour tous les modèles



Pos.	Codice	Descrizione	Description	Description
1	CEMP1823B	Sicurezza porta completa	Door plunger assembly	Sécurité porte assemblé
2	CEMP18B	Corpo posteriore sicurezza porta	Door plunger elbow	Corps postérieur
3	OR112	Or sicurezza porta	O ring 112	Joint OR 112
4	CEMPPIB	Puntale isolante astina sicurezza porta	Push rod end cap	Pointeau isolant axe sécurité porte
5	CEMP21	Astina sicurezza porta	Push rod	Axe sécurité porte
6	CEMP20	Molla sicurezza porta	Door plunger spring	Ressort sécurité porte
7	CEMP22	Seeger astina sicurezza porta	Circlip	Circlips
8	CEMP23B	Corpo anteriore sicurezza porta	Door plunger body	Corps antérieur
9	CEMP12CSC	Microinterruttore standard completo	Door switch assy complete	Micro porte complete
10	CEMP13CS	Squadretta micro porta standard	Bracket for door switch	Support interrupteur
11	CEISOMPNT	Isolante micro porta	Insulating plate	Isolateur
12	CEMP12SM	Microinterruttore	Door micro switch only	Interrupteur
13	CEMP12ACS	Leva microinterruttore standard	Operating arm, right angled	Levier micro-interrupteur
14	D038A	Dado ottone 3/8"	Brass lock nut 3/8"	Ecrou 3/8"
15	CEMP12ACL	Leva microinterruttore comandi laterali	Operating arm, right angled, lateral	Levier micro-interrupteur
16	CEMP13CL	Squadretta micro porta comandi laterali	Bracket for door switch, lateral	Support interrupteur
17	CEMP12CLC	Microinterruttore comandi laterali completo	Door switch assy complete, lateral	Micro interrupteur complet

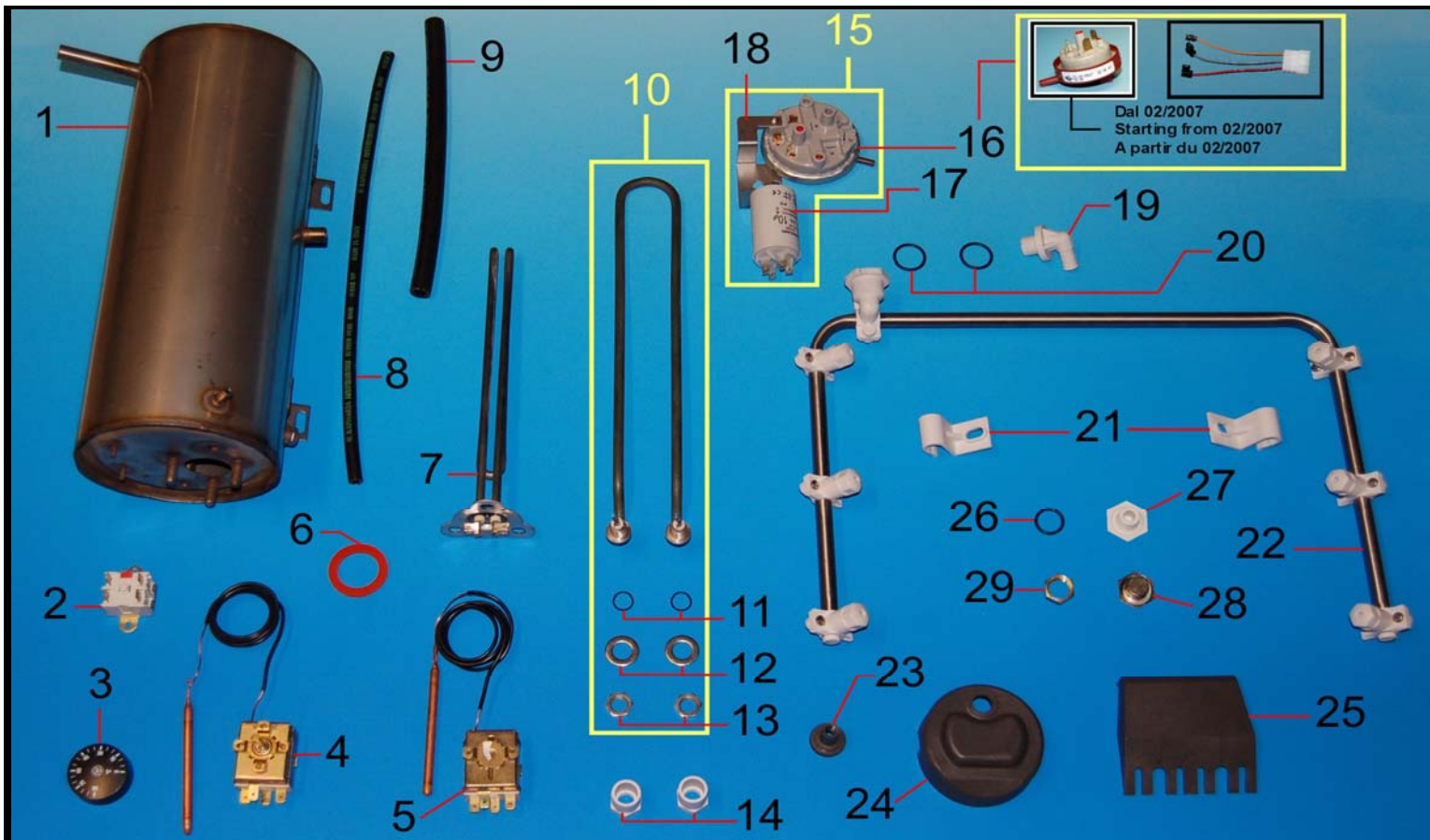

Pos.	Codice	Descrizione	Description	Description
1	GB11NT	Boiler	Boiler	Surchauffeur
2	CESB454	Termostato sicurezza boiler	Rinse safety thermal switch	Termostat sécurité surchauffeur
3	CEMTB	Manopola termostato	Knob, thermostat	Manette thermostat
4	CETB85	Termostato boiler regolabile	Adjustable control thermostat	Termostat surchauffeur réglable
5	CETV55	Termostato vasca fisso	Fixed wash control thermostat	Termostat cuve fixe
6	G42303S	Guarnizione resistenza boiler	Rinse element seal, small	Joint torique résistance surchauffeur
7	CERB2712	Resistenza boiler 2700 W	Rinse element, 2700W	Résistance surchauffeur 2700 W
8	TG510DS	Tubo gomma 5x10	R-aid tube to boiler	Tube 5x10
9	TG1117	Tubo gomma 11x17	Standard rinse hose 11mm bore	Tube 11x17
10	CERV18	Resistenza vasca 1800 W	Wash element, 1800 W	Résistance de cuve 1800 W
11	ORRV	Or resistenza vasca	O rings for wash element	Joint torique résistance cuve
12	VRP12I	Rondella piana , diam. 12 mm	Flat washer, diam. 12 mm	Rondelle, diam. 12 mm
13	VDRV	Dado resistenza vasca	Lock nut	Ecrou fixation résistance cuve
14	CEPRVV0	Protezione resistenza vasca	Protection, wash element	Protection résistance cuve
15	AM0SQPCS1C	Squadretta assemblata condensatore pressostato	Assembly, press. switch and capacitor	Support résistance condensateur
16	CEPR	Pressostato	Air pressure switch	Pressostat
17	CECN10	Condensatore, 10 mi-F	Capacitor 10 mi-F	Condensateur, 10 mi-F
18	AM0SQPCS	Squadretta inox	Bracket	Support inox
19	GRS06B	Raccordo fissaggio asta esterno	Inlet elbow	Raccord tenue rampe de rinçage
20	OR128	Or 128	O ring 128	Joint support
21	GRS05B	Gancio fissaggio asta	Securing clamp	Crochet de support rampe
22	GRS1QBCM	Asta risciacquo assemblata	Fixed rinse arm complete	Rampe de rinçage supérieure complète
23	GB09V0	Nottolino protezione boiler	Securing nut, rinse element guard, small	Ecrou fixation protection rés. surchauffeur
24	GB08V0	Protezione resistenza boiler	Rinse element guard, small	Protection résistance surchauffeur
25	CEPRTV0	Protezione termostati	Thermostat protection	Protection thermostats
26	OR122	Or 122	O ring 122	Joint torique
27	D0T38PB	Tappo 3/8 ppl	Tank plug, plastic, 3/8"	Bouchon, plastique, 3/8"
28	D0T38	Tappo 3/8 ottone	Tank plug, 3/8"	Bouchon, laiton, 3/8"
29	D038A	Dado 3/8	Brass lock nut 3/8"	Ecrou fixation support rinçage 3/8"

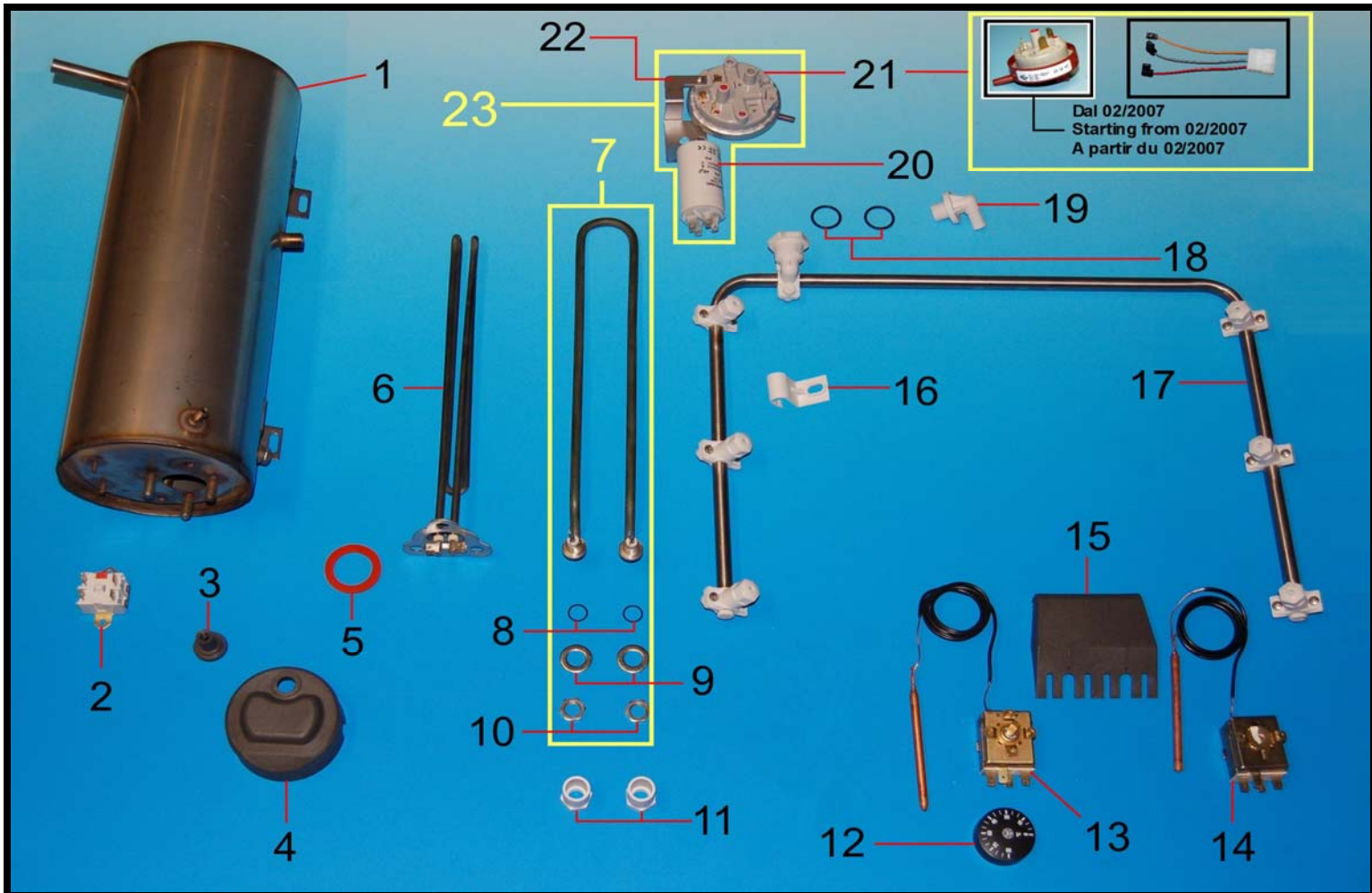

Pos.	Codice	Descrizione	Description	Description
1	GB21NT	Boiler	Boiler	Surchauffeur
2	CESB454	Termostato sicurezza boiler	Rinse safety thermal switch	Termostat sureté surchauffeur
3	GB09V0	Nottolino protezione resistenza boiler	Securing nut, rinse element guard, small	Ecrou fixation protection résistance surchauffeur
4	GB08V0	Protezione resistenza boiler	Rinse element guard, small	Protection résistance surchauffeur
5	G42303S	Guarnizione resistenza boiler	Rinse element seal, small	Joint torique résistance surchauffeur
6	CERB2712	Resistenza boiler 2700 w	Rinse element 2.7kW	Résistance surchauffeur 2,7kW
7	CERV18	Resistenza vasca 1800 w	Wash element 1.8kW	Résistance de cuve 1,8kW
8	ORRV	Or resistenza vasca	O ring for wash element	Joint torique résistance cuve
9	VRP12I	Rondella piana, diam. 12mm	Flat washer, diam. 12mm	Rondelle, diam. 12mm
10	VDRV	Dado resistenza vasca	Lock nut	Ecrou fixation résistance cuve
11	CEPRVV0	Protezione resistenza vasca	Protection, wash element	Protection résistance cuve
12	CEMTB	Manopola termostato	Knob, thermostat	Manette thermostat
13	CETB85	Termostato boiler regolabile	Adjustable control thermostat	Termostat surchauffeur
14	CETV55	Termostato vasca fisso	Fixed wash control thermostat	Termostat cuve fix
15	CEPRTV0	Protezione termostati	Thermostat protection	Protection thermostats
16	GRS05B	Gancio fissaggio asta	Securing clamp	Crochet de support rampe
17	GRS2QBCM	Asta risciacquo assemblata	Rinse arm assy	Aste de rinçage
18	OR128	Or 128	O ring 128	Joint support
19	GRS06B	Raccordo fissaggio asta esterno	Inlet elbow	Raccord fixation rampe de rinçage
20	CECN12	Condensatore	Capacitor 12,5 mi-F	Condensateur 12,5 mi-f
21	CEPR	Pressostato	Air pressure switch	Pressostat
22	AM0SQPCCS	Squadretta inox	Bracket	Support
23	AM0SQPCCS2C	Squadretta assemblata condensatore pressostato	Assembly, pressure switch and capacitor	Support résistance condensateur

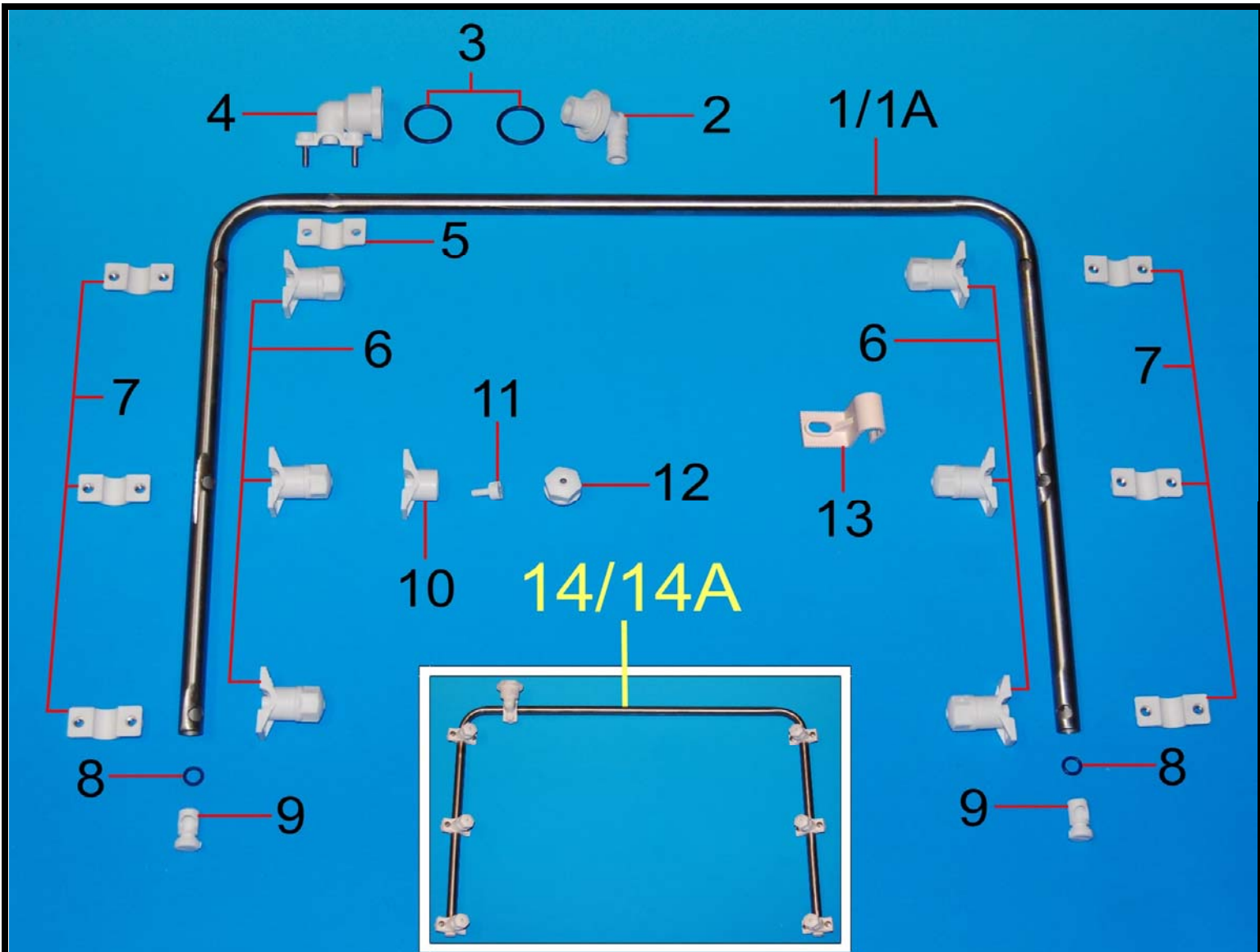

Pos.	Codice	Descrizione	Description	Description
1	GRS1Q	Asta inox mod. 35x35	Steel tube for top rinse, mod. 35x35	Rampe inox, mod. 35x35
1A	GRS2Q	Asta inox mod. 40x40	Steel tube for top rinse, mod. 40x40	Rampe inox, mod. 40x40
2	GRS06B	Raccordo fissaggio asta esterno	External rinse connection clamp	Raccord fixation rampe de rinçage extérieure
3	OR128	Or 128	O ring 128	Joint support
4	GRS03B	Raccordo asta interno	External rinse connection clamp	Raccord fixation rampe de rinçage intérieure
5	GRS04B	Cavalotto fissaggio asta	Rinse tube clamp	Support supérieur fixation rampe
6	GR019BBCOMP	Portagetto risciacquo assemblato	Rinse jet clamp assy	Support gicleur
7	GR019DB	Supporto inferiore portagetto	Rinse jet rear clamp	Support inférieur gicleur
8	OR106	Or 106	O ring door handle screw	Joint torique pour poignée
9	GR019GB	Tappo asta	Rinse arm plug	Bouchon rampe inox
10	GR019BB	Portagetto risciacquo	Rinse jet base	Support supérieur gicleur rinçage
11	GR021B	Diffusore risciacquo	Rinse jet spinner	Diffuseur de rinçage
12	GR020B	Getto risciacquo	Rinse jet	Gicleur de rinçage
13	GRS05B	Gancio fissaggio asta	Securing clamp	Crochet de support rampe
14	GRS1QBCM	Asta risciacquo assemblata, mod. 35x35	Fixed rinse arm complete, mod. 35x35	Rampe de rinçage complète, mod.35x35
14A	GRS2QBCM	Asta risciacquo assemblata, mod. 40x40	Fixed rinse arm complete, mod. 40x40	Rampe de rinçage complète, mod.40x40

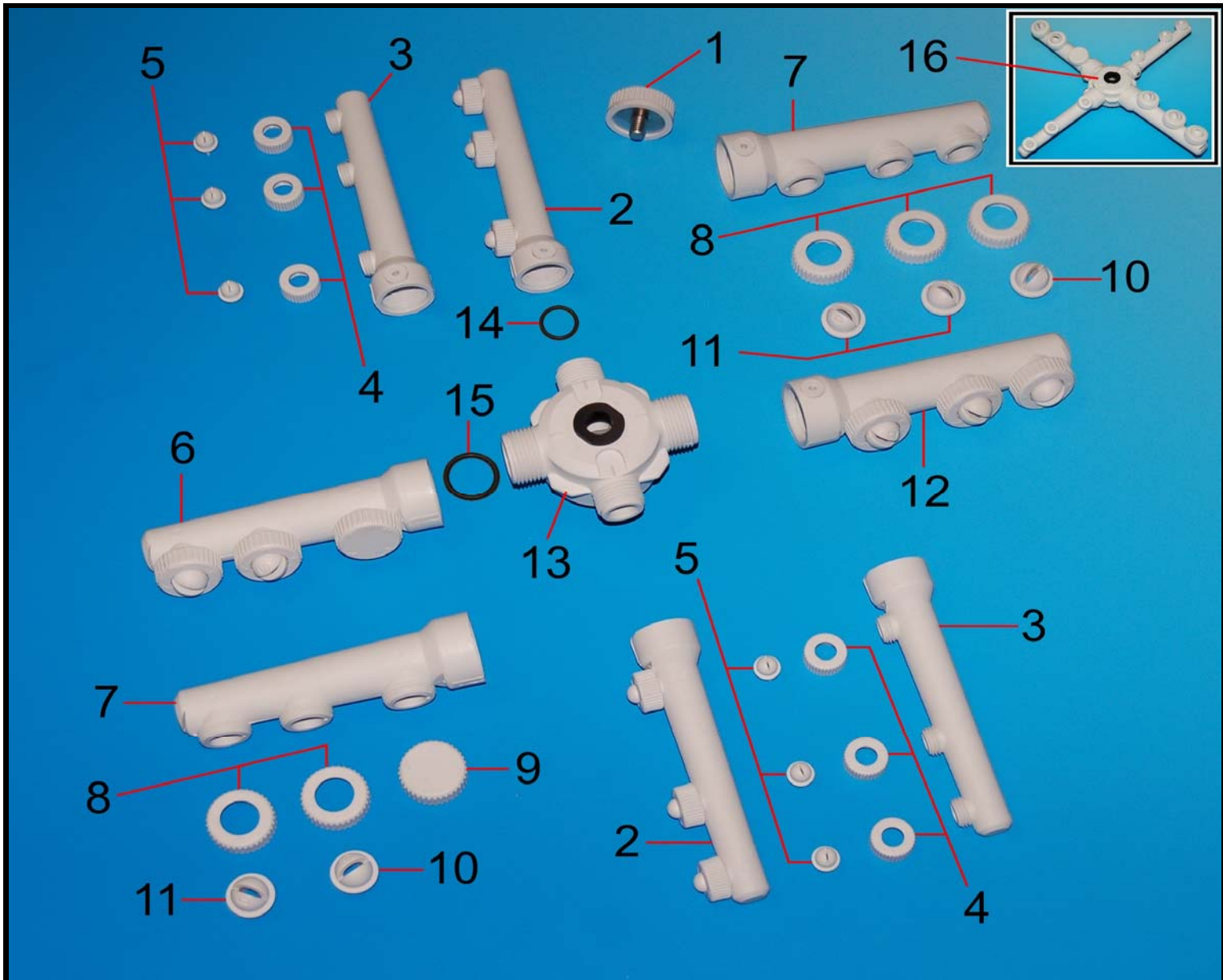

Pos.	Codice	Descrizione	Description	Description
1	LS09PB	Nottolino fissaggio girante	Spindle retaining nut	Ecrou pour pivot
2	LSI16CDSB	Asta risciacquo sinistra/destra assemblata	LH rinse arm complete	Rampe rinçage gauche/droite complèt
3	LSI16CB	Asta risciacquo	Rinse arm only	Rampe rinçage
4	LSI021B	Ghiera fissaggio getto risciacquo	Locating nut for rinse jets	Ecrou fixation gicleur rinçage
5	LSI020B	Getto risciacquo	Rinse jet	Gicleur rinçage
6	LSI16BSB	Asta lavaggio sinistra assemblata	LH wash arm, complete	Rampe lavage gauche avec gicleurs
7	LSI16BB	Asta lavaggio	Wash arm only	Rampe lavage
8	LSI017B	Ghiera fissaggio getto lavaggio	Locating nut for wash jets	Ecrou serrage gicleur lavage
9	LSI018B	Tappo getto lavaggio	Wash arm blank	Bouchon gicleur de lavage
10	LSI016B	Getto lavaggio sinistro stretto	Wash jet, LH, marked "s"	Gicleur lavage gauche
11	LSI015B	Getto lavaggio destro stretto	Wash jet, RH marked "d"	Gicleur lavage droite
12	LSI16BDB	Asta lavaggio destra assemblata	RH wash arm complete	Rampe lavage droite avec gicleurs
13	LSI0607AB	Mozzo girante	Centre boss c/w bushes	Moyeu central avec bagues
14	OR118	Or 118	O ring 118	Joint torique rampe rinçage
15	OR124	Or 124	O ring 124	Joint torique rampe lavage
16	LSI16BBB	Girante completa assemblata	Rotating wash assy complete	Tourniquet complet assemblé

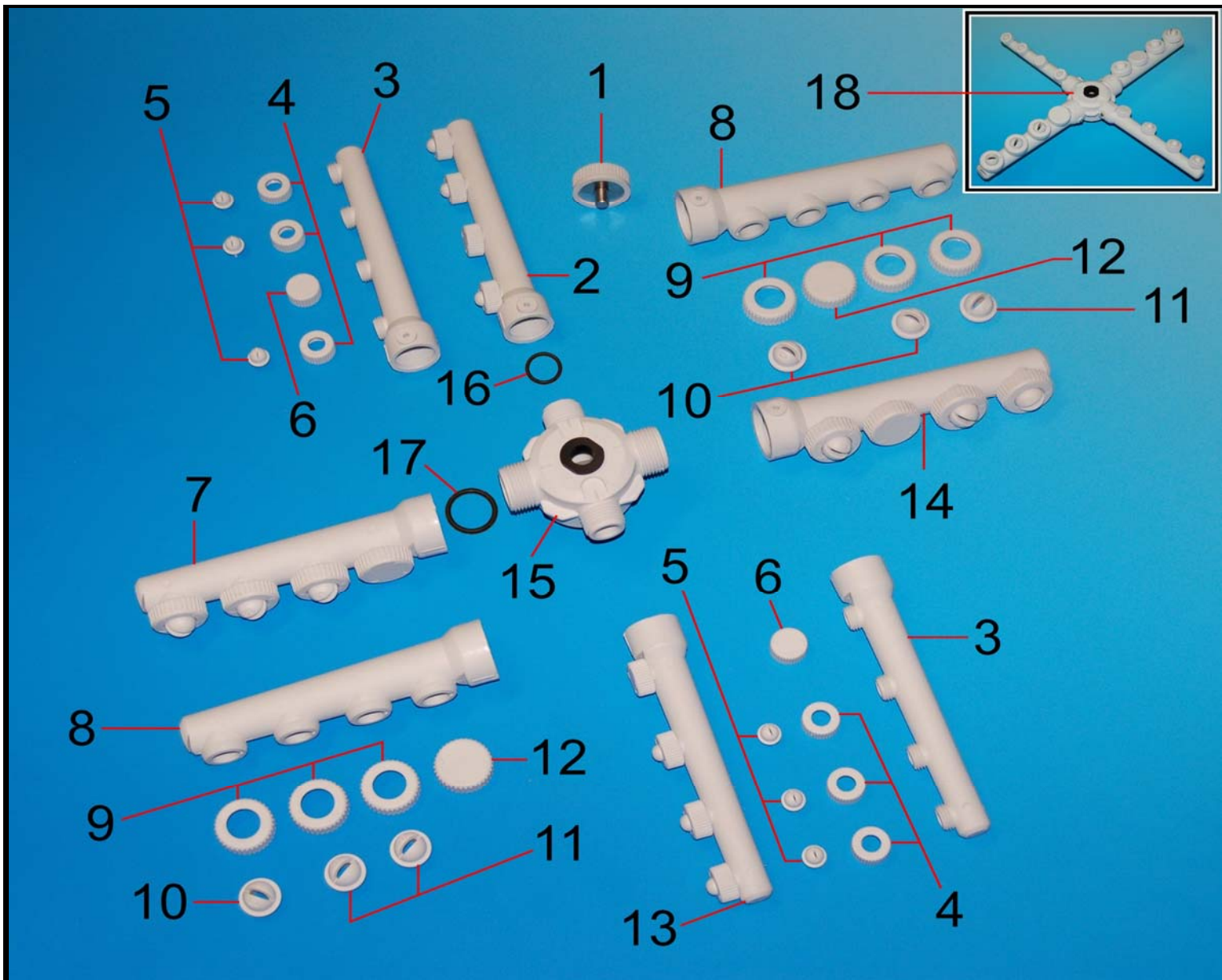

Pos.	Codice	Descrizione	Description	Description
1	LS09PB	Nottolino fissaggio girante	Spindle retaining nut	Ecrou pour pivot
2	LSI26CSB	Asta risciacquo sinistra assemblata congetti	Rinse arm with jets, LH	Rampe rinçage gauche, avec gicleur
3	LSI26CB	Asta risciacquo	Rinse arm only	Rampe rinçage
4	LSI021B	Ghiera fissaggio getto risciacquo	Locating nut for rinse jets	Ecrou fixation gicleur rinçage
5	LSI020B	Getto risciacquo	Rinse jet	Gicleur rinçage
6	LSI022B	Tappo getto risciacquo	Blank for rinse arm	Bouchon
7	LSI26BSB	Asta lavaggio sinistra assemblata con getti	LH wash arm complete	Rampe lavage gauche, avec gicleur
8	LSI26BB	Asta lavaggio	Wash arm only	Rampe lavage
9	LSI017B	Ghiera fissaggio getto lavaggio	Locating nut for wash jets	Ecrou fixation gicleur lavage
10	LSI015B	Getto lavaggio destro stretto	Wash jet, RH marked "D"	Gicleur lavage droite
11	LSI016B	Getto lavaggio sinistro stretto	Wash jet, LH, marked "D"	Gicleur lavage gauche
12	LSI018B	Tappo getto lavaggio	Wash arm blank	Bouchon
13	LSI26CDB	Asta risciacquo destra assemblata	RH rinse arm complete	Rampe rinçage droite complète
14	LSI26BDB	Asta lavaggio destra assemblata	RH wash arm complete	Rampe lavage droite complète
15	LSI0607AB	Mozzo girante	Centre boss c/w bushes	Moyeu central avec bagues
16	OR118	Or 118	O ring 118	Joint torique rampe rinçage
17	OR124	Or 124	O ring 124	Joint torique rampe lavage
18	LSI26BBB	Girante completa assemblata	Rotating wash assy complete	Tourniquet complet assemblé

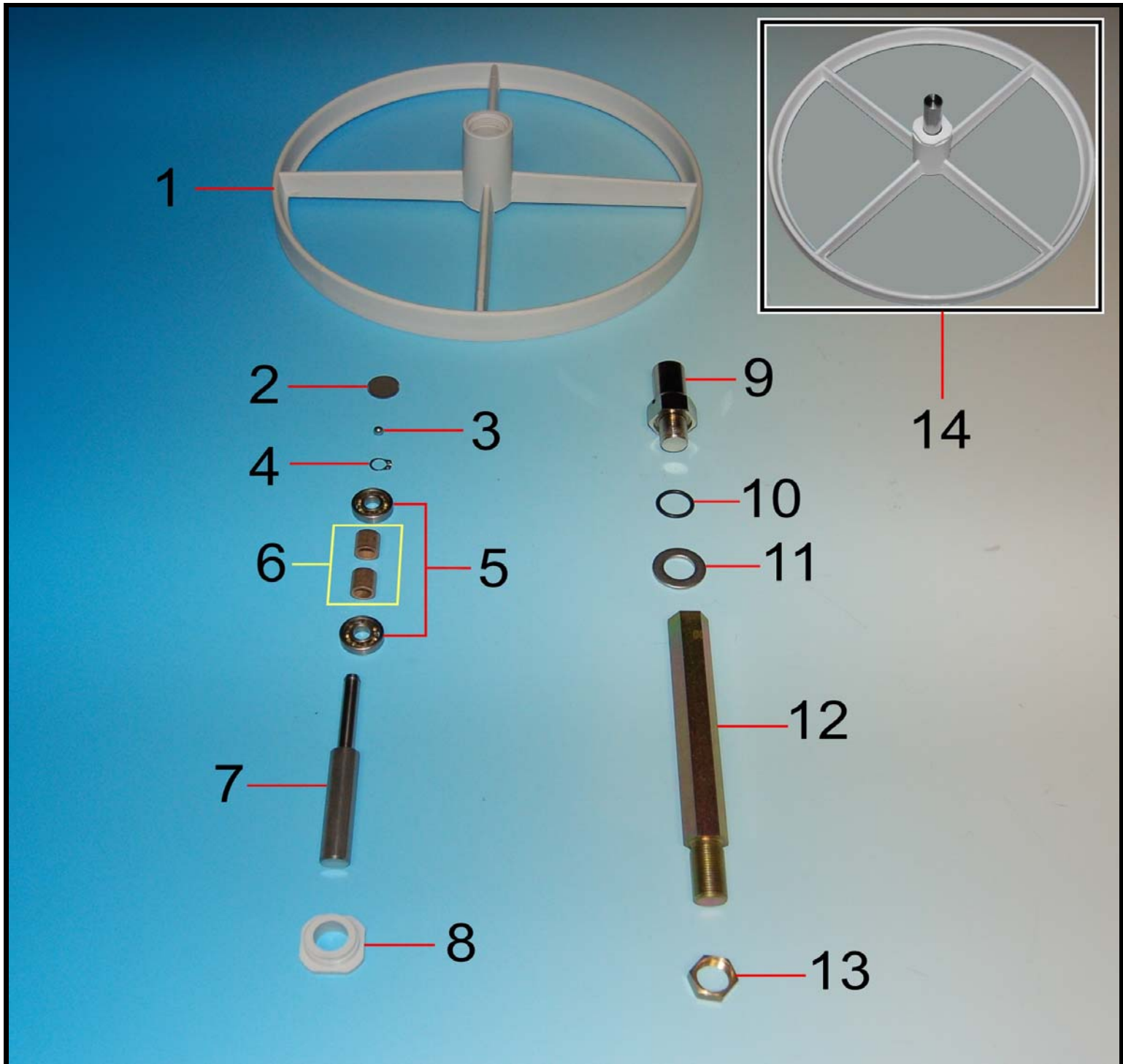

Pos.	Codice	Descrizione	Description	Description
1	GG1TAB	Girello parte ppl	Turntable	Tourniquet
2	GG1TB	Dischetto inox	Steel bearing ring	Petit disque inox
3	GG1T1E	Sfera girello piccolo	Seal	Joint
4	GG1TE	Seeger	Circlip for turntable	Circlip
5	GG1TC	Cuscinetto per girello girante	Ball bearing for turntable	Roulement inox
6	GG1TD	Distanziale albero girello	Spacer for turntable	Entretoise
7	GG1TFEG	Perno girello con sfera	Stud turntable with ball	Tourillon tourniquet avec bille
8	GG1THB	Ghiera fissaggio perno girello	Ring nut for turntable	Ecrou plastique
9	GG1T2	Supporto girello	Support for turntable	Support tourniquet
10	OR122	Or 122	O-ring 122	Joint
11	GG0T4	Rondella piana Ø 16	Flat washer, diam 16 mm	Rondelle, diam 16 mm
12	GG1T5	Tirante esagonale	Hexagonal spacer column	Tirant hexagonal
13	DO38A	Dado 3/8	Brass lock nut 3/8"	Ecrou tenue support rinçage
14	GG1T1	Girello completo assemblato	Turntable assembly	Volant complet

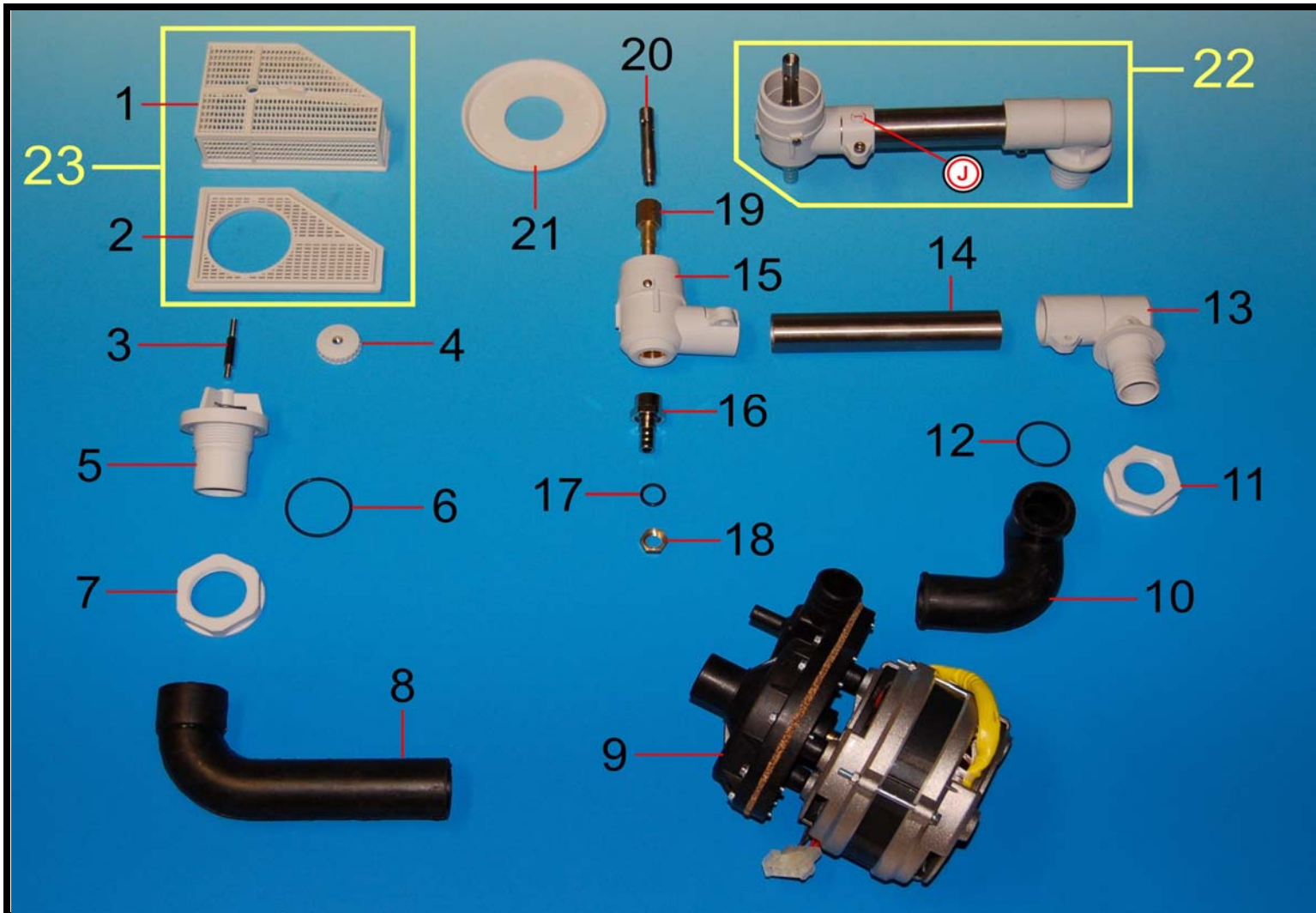

Pos.	Codice	Descrizione	Description	Description
1	GA115R	Filtro aspirazione	Plastic filter upper body	Filtere d'aspiration
2	GA115RA	Piastra filtro aspirazione	Plastic filter base	Plaque inférieure filtre
3	GAGS1299	Astina filtro	Filter spindle	Tige de filtre
4	GA013B	Nottolino filtro	Filter retaining nut	Ecrou de filtre
5	GA111B	Piletta aspirazione	Drain filter boss	Bonde d'aspiration
6	OR3168	Or 3168	O-ring 3168	Joint 3168
7	DP114	Dado 1" 1/4	Plastic nut 1"1/4	Ecrou plastique 1"1/4
8	GA18	Manicotto aspirazione	Inlet hose	Durite d'aspiration
9	EP30	Elettropompa	Wash pump complete, 0.3 HP	Pompe de lavage, 0,3 HP
10	GL1T22	Manicotto mandata	Outlet hose	Durite de refoulement
11	DP1	Dado 1"	Nut 1"	Ecrou plastique , 1"
12	OR3131	Or 3131	O-ring 3131	Joint torique pour colonne
13	LI126FCB	Piletta entrata lavaggio	Wash elbow and column	Bonde entrée complète
14	LI12830	Tubo inox interno	Wash extension tube	Tube inox
15	LI029CJB	Supporto inferiore	Bottom boss assy	Support inférieur complet
16	LI133FOT	Supporto risciacquo	Rinse support	Support rinçage
17	OR117	Or 117	O-ring 117	Joint torique pour bouchon
18	D014	Dado 1/4"	Brass nut 1/4"	Ecrou 1/4"
19	LI130	Prolunga perno	Spindle extension	Extension pivot
20	LI18F	Perno inox	Stainless steel upper spindle	Pivot inox rinçage
21	LI034P	Piattello inferiore	Deflector disk	Défecteur
22	GLICQ1JBCOMP	Gruppo inferiore completo assemblato	Lower elbow and boss assy complete	Groupe inférieure complet
23	GA115RCOMP	Filtro aspirazione completo	Plastic filter, complete	Filtere d'aspiration complet

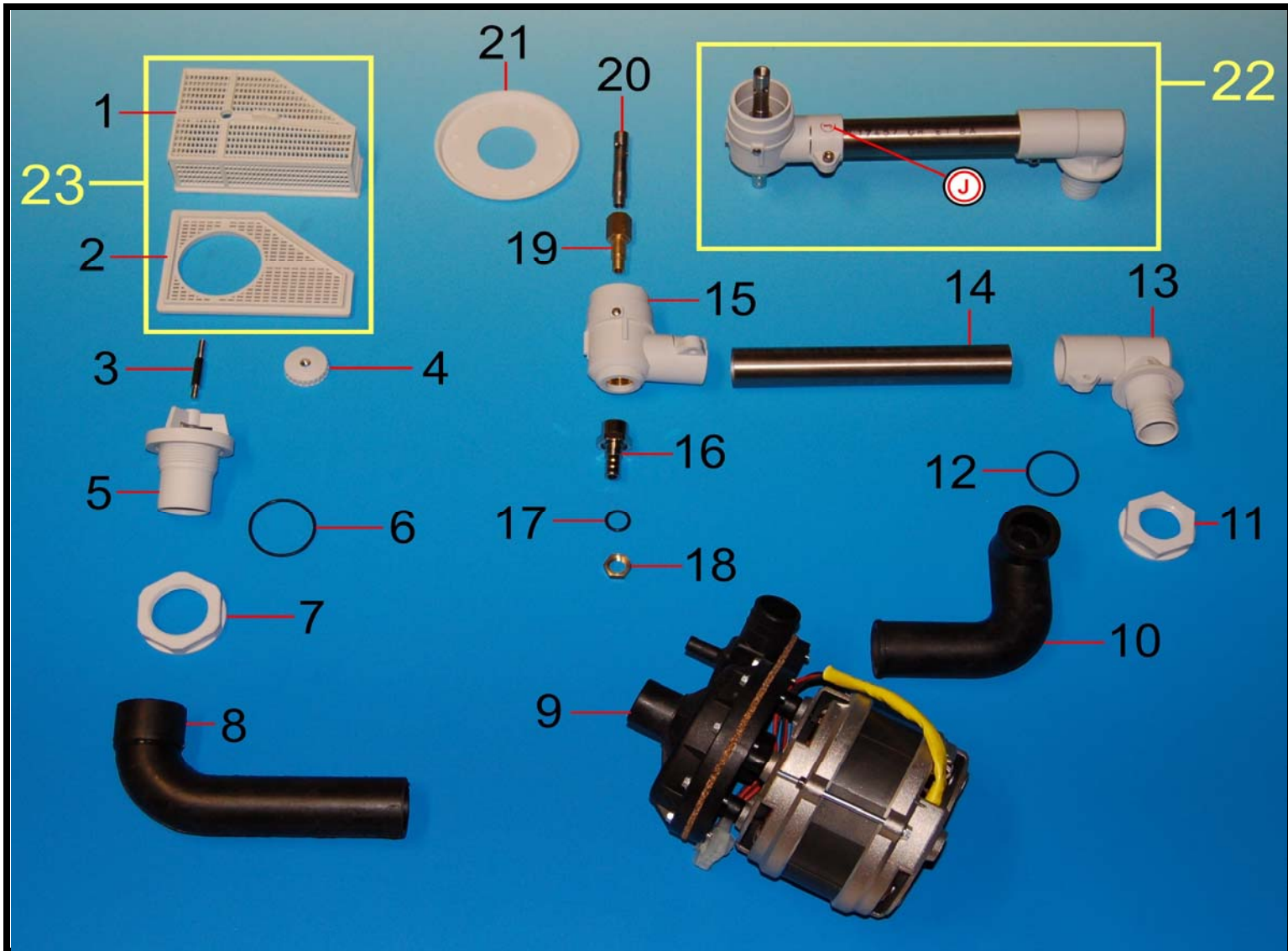

Pos.	Codice	Descrizione	Description	Description
1	GA115R	Filtro aspirazione	Plastic filter upper body	Filtre d'aspiration
2	GA115RA	Piastra filtro aspirazione	Plastic filter base	Plaqué inférieur filtre
3	GAGS1299	Astina filtro	Filter spindle	Tige de filtre
4	GA013B	Nottolino filtro	Filter retaining nut	Ecrou de filtre
5	GA111B	Piletta aspirazione	Drain filter boss	Bonde d'aspiration
6	OR3168	Or 3168	O-ring 3168	Joint OR 3168
7	DP114	Dado 1" ¼	Plastic nut, 1"1/4	Ecrou plastique , 1"1/4
8	GA18	Manicotto aspirazione	Inlet hose	Durite d'aspiration
9	EP60	Elettropompa	Wash pump complete 0.6 HP	Pompe de lavage, 6,0 Hp
10	GL2T22	Manicotto mandata	Outlet hose	Durite de réoulement
11	DP1	Dado 1"	Nut 1"	Ecrou plastique
12	OR3131	Or 3131	O-ring 3131	Joint torique pour colonne
13	LI126FCB	Piletta entrata lavaggio	Wash elbow and column	Bonde entrée complète
14	LI22830	Tubo inox interno	Wash extension tube	Tuyau inox
15	LI029CBB	Supporto inferiore	Bottom boss assy	Support inférieur complet
16	LI133FOT	Supporto risciacquo	Rinse support	Support rinçage
17	OR117	Or 117	O ring 117	Joint torique pour bouchon
18	D014	Dado ¼"	Brass nut 1/4"	Ecrou 1/4"
19	LI130	Prolunga perno	Spindle extension	Extension pivot
20	LI18F	Perno inox corto	Stainless steel upper spindle	Pivot inox rinçage
21	LI034P	Piattello inferiore	Deflector disk	Défecteur
22	GLICQ2JBCOMP	Gruppo inferiore completo assemblato	Lower elbow and boss assy complete	Groupe inférieur complet
23	GA115RCOMP	Filtro aspirazione completo	Plastic filter, complete	Filtre d'aspiration complete

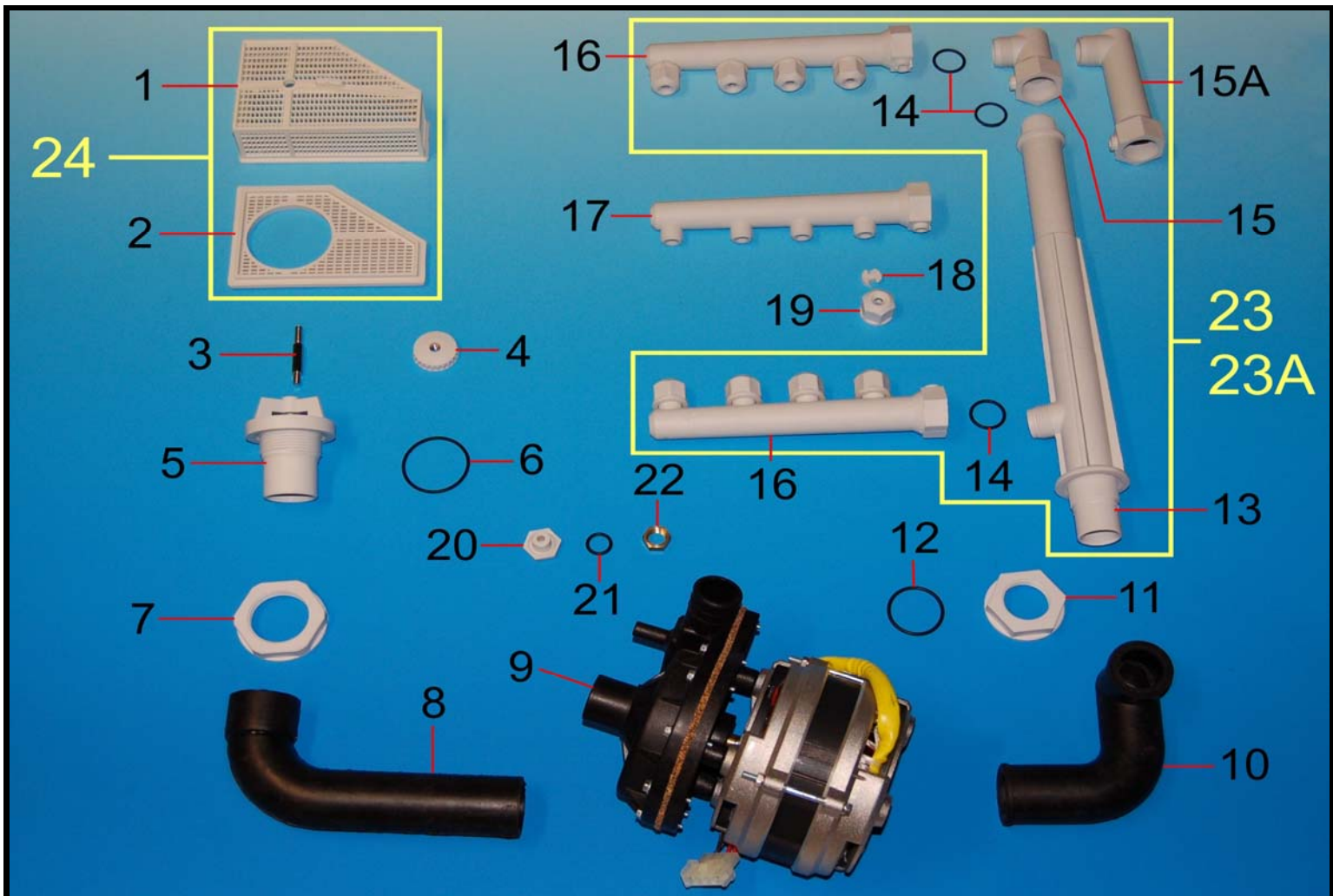

Pos.	Codice	Descrizione	Description	Description
1	GA115R	Filtro aspirazione	Plastic filter upper body	Filtre d'aspiration
2	GA115RA	Piastra filtro aspirazione	Plastic filter base	Plaqué inférieure filtre
3	GAGS1299	Astina filtro	Filter spindle	Tige de filtre
4	GA013B	Nottolino filtro	Filter retaining nut	Ecrou de filtre
5	GA111B	Piletta aspirazione	Drain filter boss	Bonde d'aspiration
6	OR3168	Or 3168	O-ring 3168	Joint 3168
7	DP114	Dado 1" ¼	Plastic nut	Ecrou plastique , 1"1/4
8	GA18	Manicotto aspirazione	Inlet hose	Durite d'aspiration
9	EP30	Elettropompa	Wash pump complete, 0.3 HP	Pompe de lavage, complète
10	GL1T22	Manicotto mandata	Outlet hose	Durite de réoulement
11	DP1	Dado 1"	Nut 1"	Ecrou plastique , 1"
12	OR3131	Or 3131	O-ring 3131	Joint torique pour colonne
13	GL1T27B	Colonna lavaggio	Wash column	Colonne de lavage
14	OR128	Or 128	O-ring 128	Joint support
15	GL1T32B	Prolunga colonna mod.1	Wash column spacer, mod.1	Extension colonne de lavage, mod.1
15A	GL2T32B	Prolunga colonna mod.1 alta	Wash column spacer, mod. 1 high	Extension colonne lavage, mod. 1 haute
16	GL1T28BCM	Asta lavaggio completa	Wash arm assembly	Rampe de lavage complète
17	GL1T28PB	Asta lavaggio	Wash arm	Rampe de lavage
18	GL031B	Diffusore getto lavaggio	Wash jet spinner	Diffuseur de lavage
19	GL030B	Getto lavaggio	Wash jet	Gicleur de lavage
20	D0T14PB	Tappo ¼ ppl	Tank plug 1/4"	Bouchon 1/4"
21	OR117	Or 117	O-ring 117	Joint torique pour bouchon
22	D014	Dado ¼"	Brass nut 1/4"	Ecrou 1/4"
23	GL1T27BC	Colonna lavaggio mod.1 completa	Wash column assembly, mod. 1	Colonne de lavage, mod.1, complète
23A	GL1AT27BC	Colonna lavaggio mod.1 alta completa	Wash column assembly, mod. 1 high	Colonne lavage, mod.1 haute, complète
24	GA115RCOMP	Filtro aspirazione completo	Plastic filter, complete	Filtre d'aspiration complet

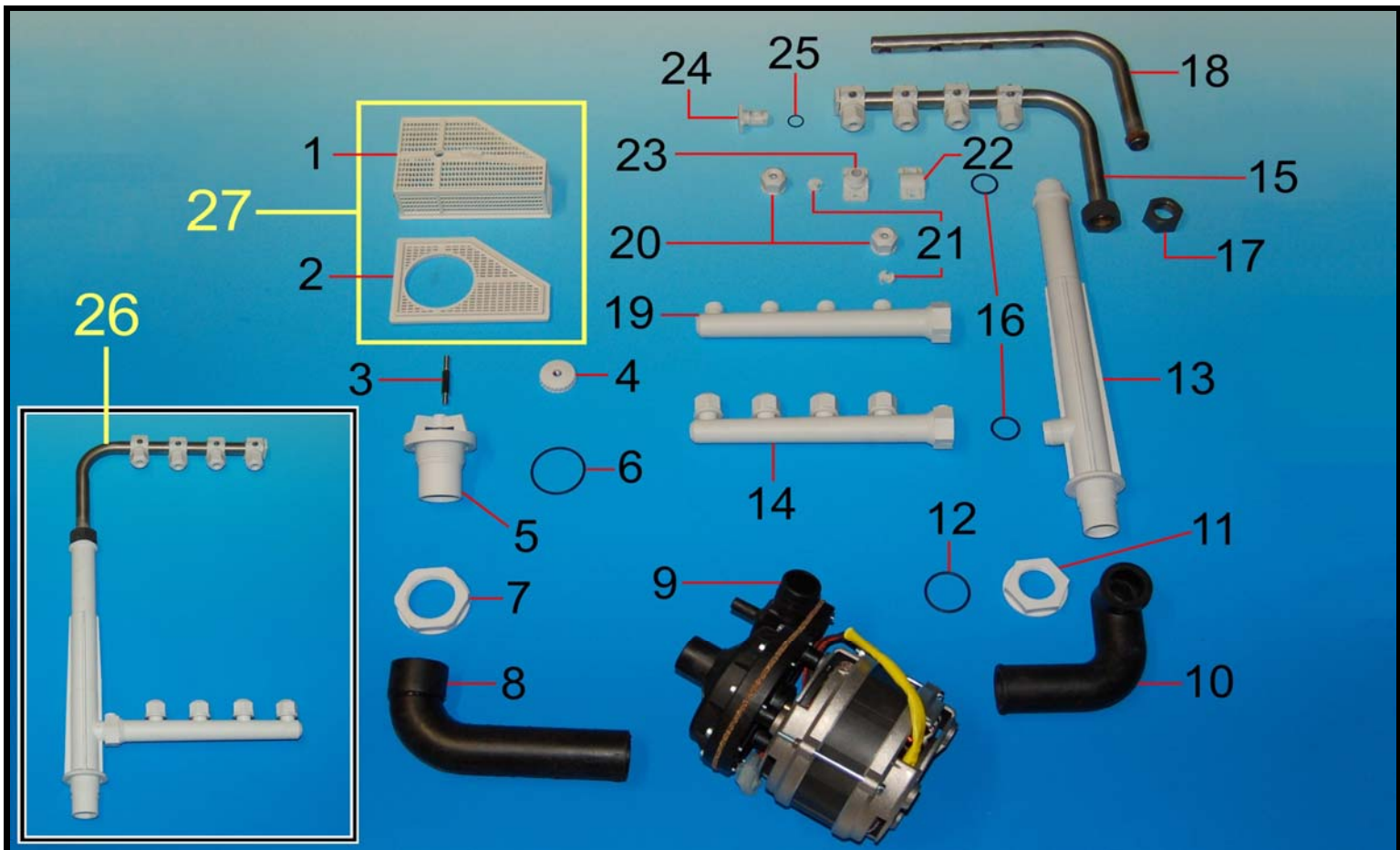

Pos.	Codice	Descrizione	Description	Description
1	GA115R	Filtro aspirazione	Plastic filter upper body	Filtre d'aspiration
2	GA115RA	Piastra filtro aspirazione	Plastic filter base	Plaqué inférieur filtre
3	GAGS1299	Astina filtro	Filter spindle	Tige de filtre
4	GA013B	Nottolino filtro	Filter retaining nut	Ecrou de filtre
5	GA111B	Piletta aspirazione	Drain filter boss	Bonde d'aspiration
6	OR3168	Or 3168	O-ring 3168	Joint OR 3168
7	DP114	Dado 1" ¼	Plastic nut, 1"1/4	Ecrou plastique , 1"1/4
8	GA18	Manicotto aspirazione	Inlet hose	Durite d'aspiration
9	EP60	Elettropompa	Wash pump complete 0.6 HP	Pompe de lavage, 6,0 Hp
10	GL2T22	Manicotto mandata	Outlet hose	Durite de réfolement
11	DP1	Dado 1"	Nut 1"	Ecrou plastique pour bonde
12	OR3131	Or 3131	O-ring 3131	Joint torique pour colonne
13	GL1T27B	Colonna lavaggio	Wash column	Colonne lavage
14	GL2T28BCM	Asta lavaggio inferiore completa	Lower wash arm assembly	Rampe de lavage inferieure complète
15	GL2AT28CMI	Asta lavaggio superiore completa	Upper wash arm assembly	Rampe de lavage superieure complète
16	OR128	Or 128	O ring 128	Joint support
17	GL34T27AB	Dado fissaggio asta	Lock nut	Ecrou fixation
18	GL2T28I	Asta lavaggio superiore inox	Upper wash arm, steel	Rampe de lavage inferieure
19	GL2T28PB	Asta lavaggio inferiore	Lower wash arm	Rampe de lavage superieure
20	GL030B	Getto lavaggio	Wash jet	Gicleur de lavage
21	GL031B	Diffusore getto lavaggio	Wash jet spinner	Diffuseur de lavage
22	GL033B	Supporto getto lavaggio inferiore	Rear clamp plate	Support inférieur gicleur lavage
23	GL032B	Supporto getto lavaggio superiore	Wash jet base	Support supérieur gicleur lavage
24	GL034AB	Tappo asta lavaggio superiore	Wash arm plug	Bouchon rampe
25	OR2050	Or 2050	O ring 2050	Joint 2050
26	GL2T27BC	Colonna lavaggio completa assemblata	Wash column assembly, complete	Colonne de lavage complète
27	GA115RCOMP	Filtro aspirazione completo	Plastic filter, complete	Filtre d'aspiration complete

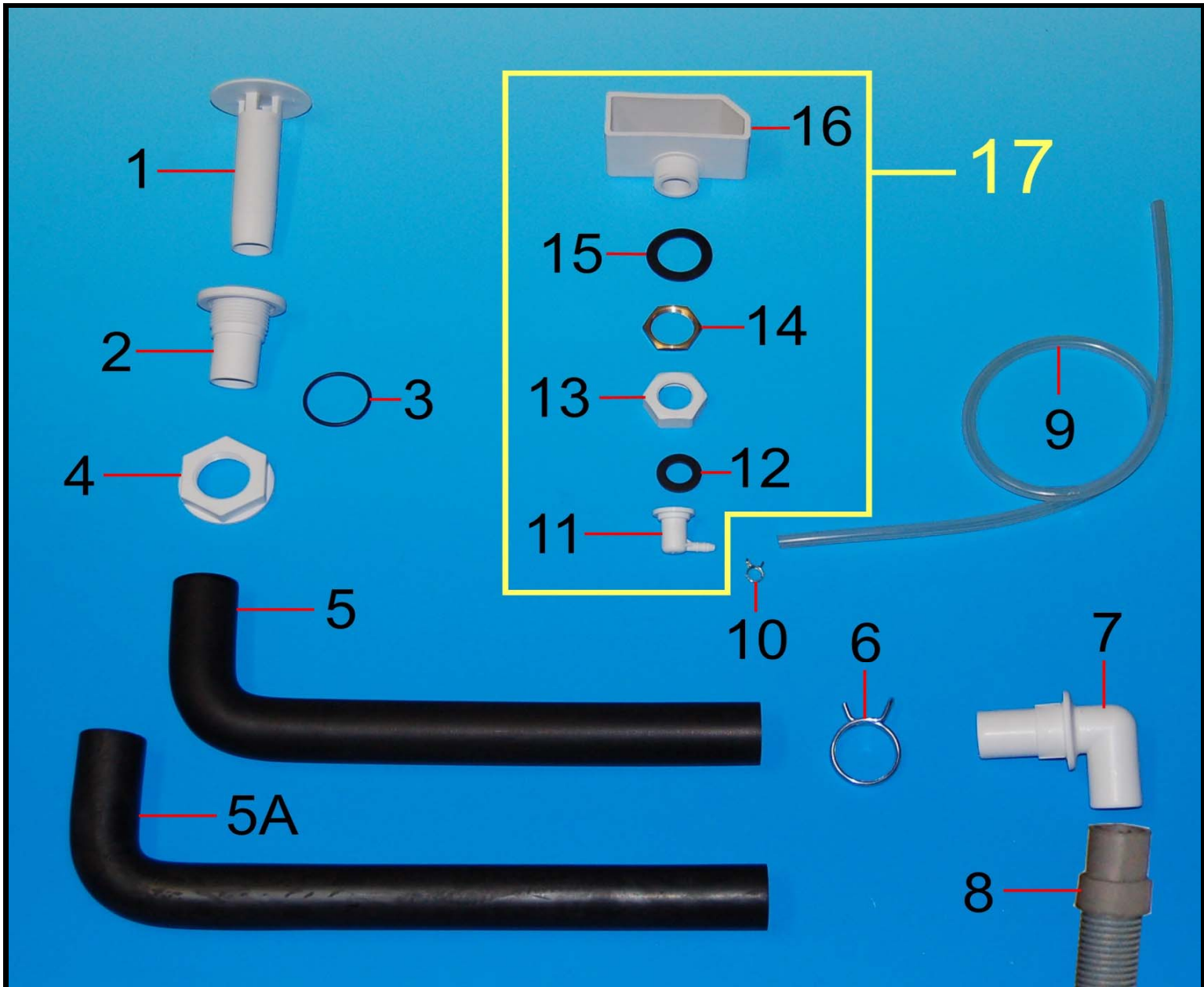

Pos.	Codice	Descrizione	Description	Description
1	GS116CCAB	Troppo pieno	Drain plug or standpipe	Bonde trop-plein, complet
2	GS117B	Piletta di scarico	Drain outlet boss	Bonde de vidange
3	OR3131	Or 3131	O-ring 3131	Joint torique pour colonne
4	DP1	Dado 1"	Nut 1"	Ecrou plastique
5	GS120	Manicotto di scarico mod.1	Drain hose, mod. 1	Durite de vidange, mod. 1
5A	GS220	Manicotto di scarico mod.2	Drain hose, mod. 2	Durite de vidange, mod. 2
6	FAM3040	Fascetta a molla	Hose clip 30-40	Collier élastique
7	GS121	Raccordo scarico 90°	Drain elbow 90°	Raccord de vidange à 90°
8	GS130	Tubo di scarico	Drain hose	Tube de vidange
9	TSIL48	Tubo silicone	Rinse-aid tube	Tube de vidange
10	FAM58	Fascetta a molla	Spring clip	Collier
11	GP026AB	Raccordo girevole	Air trap elbow	Raccord tournant
12	G251525G	Guarnizione raccordo girevole	Sealing washer	Joint raccord tournant
13	GP026BB	Dado raccordo girevole	Air tap elbow nut	Ecrou pour raccord tournant
14	D034	Dado ¾"	Brass nut, 3/4"	Ecrou 3/4"
15	G382615G	Guarnizione trappola aria	Air trap seal	Joint
16	GP025B	Trappola aria	Air trap	Chambre de compression
17	GP025BCOMP	Trappola aria completa	Pressure vessel assy complete	Chambre de compression, complète

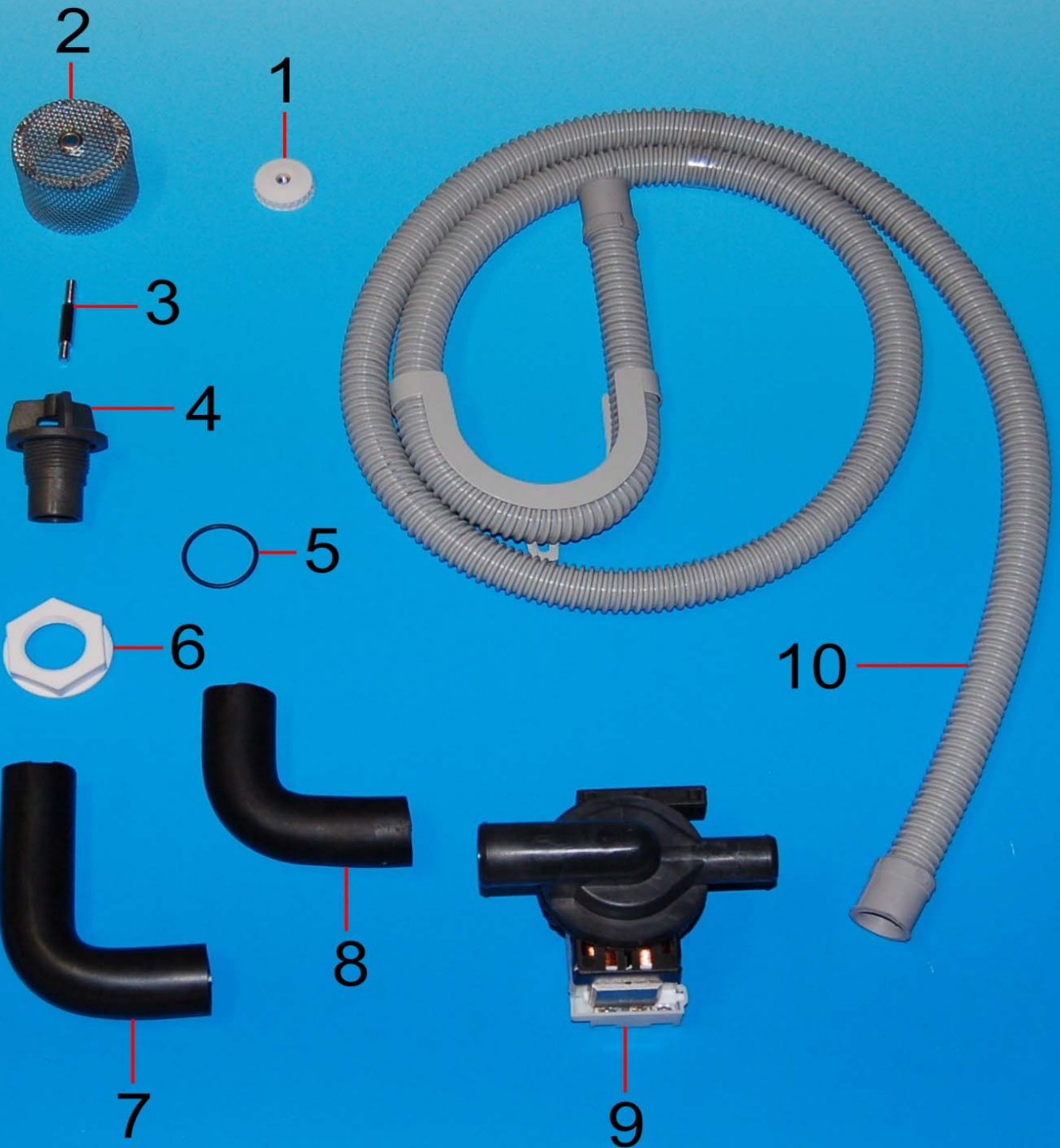

Pos.	Codice	Descrizione	Description	Description
1	GA013B	Nottolino filtro	Filter retaining nut	Ecrou de filtre
2	GAFAPS199	Filtro aspirazione pompa scarico	Drain pump Filter	Filtre pompe de vidange
3	GAGS1299	Astina filtro	Filter spindle	Tige de filtre
4	GAPS1299B	Piletta aspirazione pompa scarico	Drain boss	Bonde de vidange
5	OR3131	Or 3131	O-ring 3131	Joint torique pour colonne
6	DP1	Dado 1"	Nut 1"	Ecrou plastique
7	GS120SPEC1	Manicotto aspirazione, mod. 1-1alta	Inlet hose, mod. 1	Durite d'aspiration, mod. 1-1 haut
8	GS120SPEC	Manicotto aspirazione, mod. 2	Inlet hose, mod. 2	Durite d'aspiration, mod. 2
9	CEPS5	Pompa scarico	Drain pump	Pompe de vidange
10	CEPS032	Tubo pompa scarico	Waste outlet hose (drain pump)	Tuyau de vidange

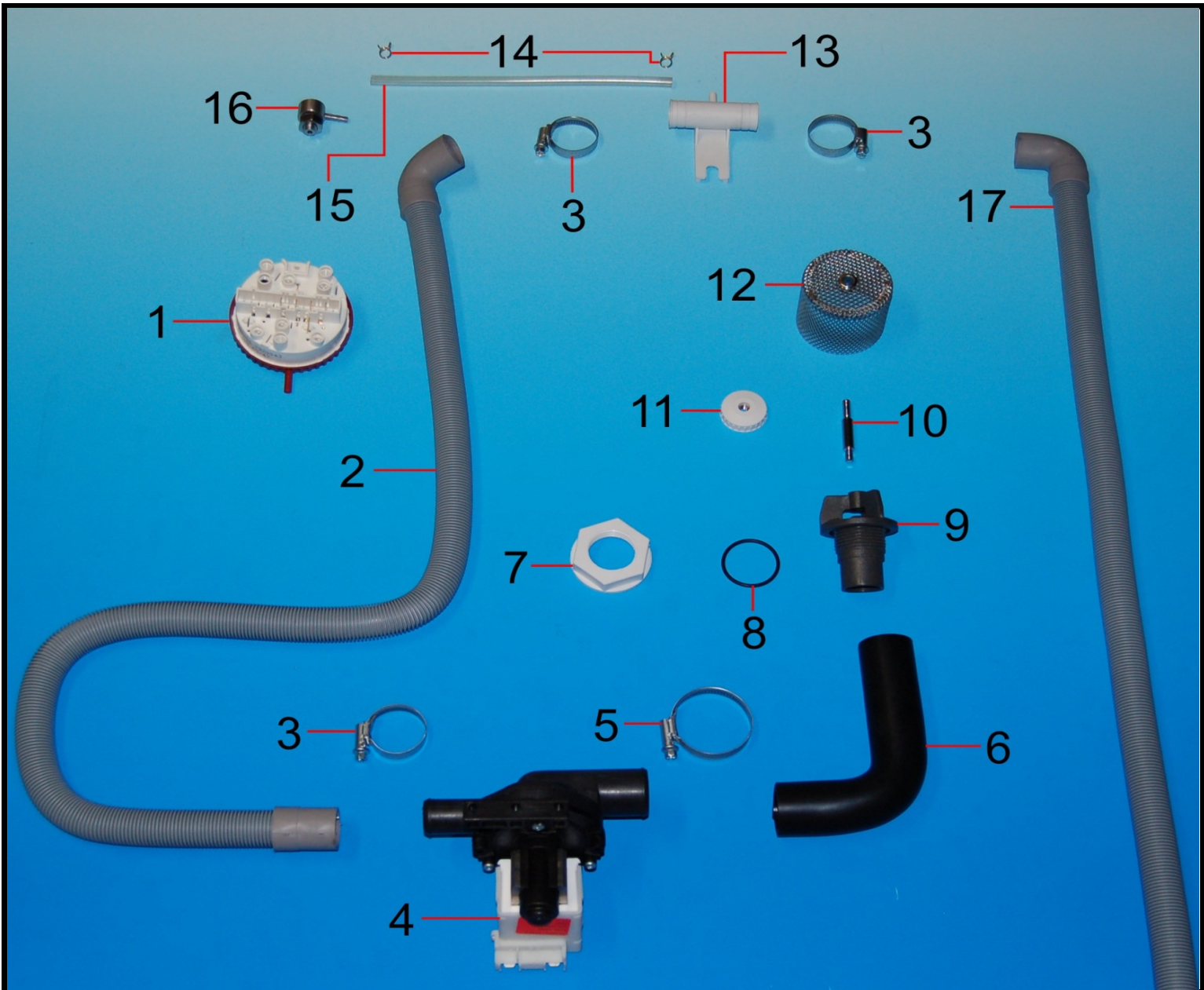

Pos.	Codice	Descrizione	Description	Description
1	CEPRE2LUL	Pressostato 2 livelli	Double air pressure switch	Pressostat 2 niveaux
2	GSTS820PS	Tubo scarico l.820 mm	Internal drain hose	Tuyau de vidange 1,820 mm
3	FA2532	Fascetta	Hose clip 25-32	Collier
4	CEPS5	Pompa scarico	Drain pump	Pompe de vidange
5	FA3040	Fascetta	Hose clip 30-40	Collier elastique
6	GS120SPEC	Manicotto aspirazione	Inlet hose	Durite d'aspiration
7	DP1	Dado 1"	Nut 1"	Ecrou plastique
8	OR3131	Or 3131	O-ring 3131	Joint torique
9	GAPS1299B	Piletta aspirazione pompa scarico	Drain boss	Bonde d'aspiration pompe de vidange
10	GAGS1299	Astina filtro	Filter spindle	Tige de filtre
11	GA013B	Nottolino filtro	Filter retaining nut	Ecrou de filtre
12	GAFAPS199	Filtro aspirazione pompa scarico	Drain pump filter	Filtre pompe de vidange
13	CEPSVSF	Valvola non ritorno scarico	Drain non return valve	Valve non retour, vidange
14	FAM710	Fascetta a molla	Spring clip	Collier
15	TSIL48	Tubo silicone	Silicone tube	Tuyau silicone
16	GSDETPI10COMP	Portagomma inox completo	Conn'n elbow, steel, complete assy	Support inox complete
17	GSTS2500PS	Tubo scarico l.2500 mm	External drain outlet hose	Tuyau de vidange l,2500 mm

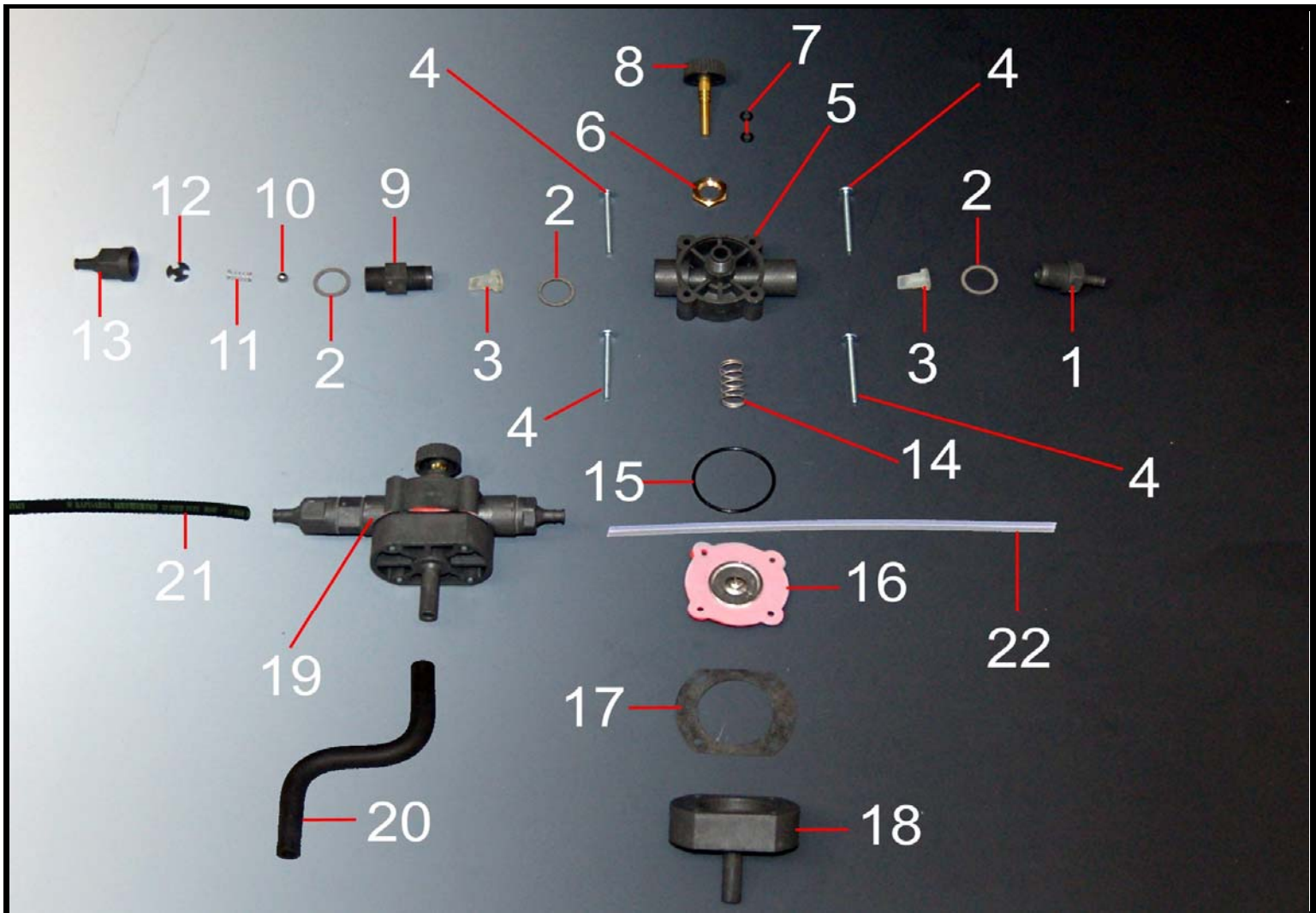

Pos.	Codice	Descrizione	Description	Description
1	DS10NT	Raccordo stringitubo	Inlet nipple	Raccord
2	G16221F	Guarnizione fibra 17x22x1,5	Seal for injector	Joint pour injecteur
3	DS8S	Valvolina silicone	Non return valve, rubber	Soupape en silicone
4	VVTCC445Z	Vite fissaggio	Special screw	Vis serrage
5	DS3	Corpo dosatore	Injector front body	Corps doseur produit de rinçage
6	DS24	Dado 20x4x14	Brass nut 20x4x14	Ecrou 20x4x14
7	OR103	Or 103	O ring 103	Or 103
8	DS1	Volantino dosatore	Adjusting screw	Manette pour doseur
9	DSVNR12	Raccordo valvola non ritorno	Housing for non return valve	Raccord soupape
10	DSVNR13	Sfera 1/4"	1/4" Ball for non return valve	Bille 1/4"
11	DSVNR14	Molla valvola non ritorno	Spring for non return valve	Ressort clapet anti retour
12	DSVNR16	Dischetto valvola non ritorno	Special disk for non return valve	Petit disque clapet anti retour
13	DSVNR17NT	Raccordo stringitubo valvola non ritorno	Outlet nipple	Raccord clapet anti retour
14	DS4	Molla membrana	Spring for diaphragm	Ressort pour membrane
15	OR422	Or 42x2	O ring 42x2	Or 42x2
16	DS06M3	Membrana completa	Diaphragm	Membrane
17	DS15	Guarnizione 64x50x1	Seal 64x50x1 for diaphragm	Joint 64x50x1
18	DS15A	Supporto posteriore	Injector rear body	Support postérieur
19	DSAM3NT	Dosatore brillantante completo assemblato	Rinse aid injector, complete	Doseur produit de rinçage
20	DS227	Tubo dosatore pompa piccola	Injector operating hose, small	Tube, doseur , petite pompe
21	TG510DS	Tubo dosatore 5x10	Rinse aid tube to boiler	Tube doseur 5x10
22	TSIL48	Tubo silicone 4x8	Silicone rinse aid inlet tube	Tube silicone 4x8

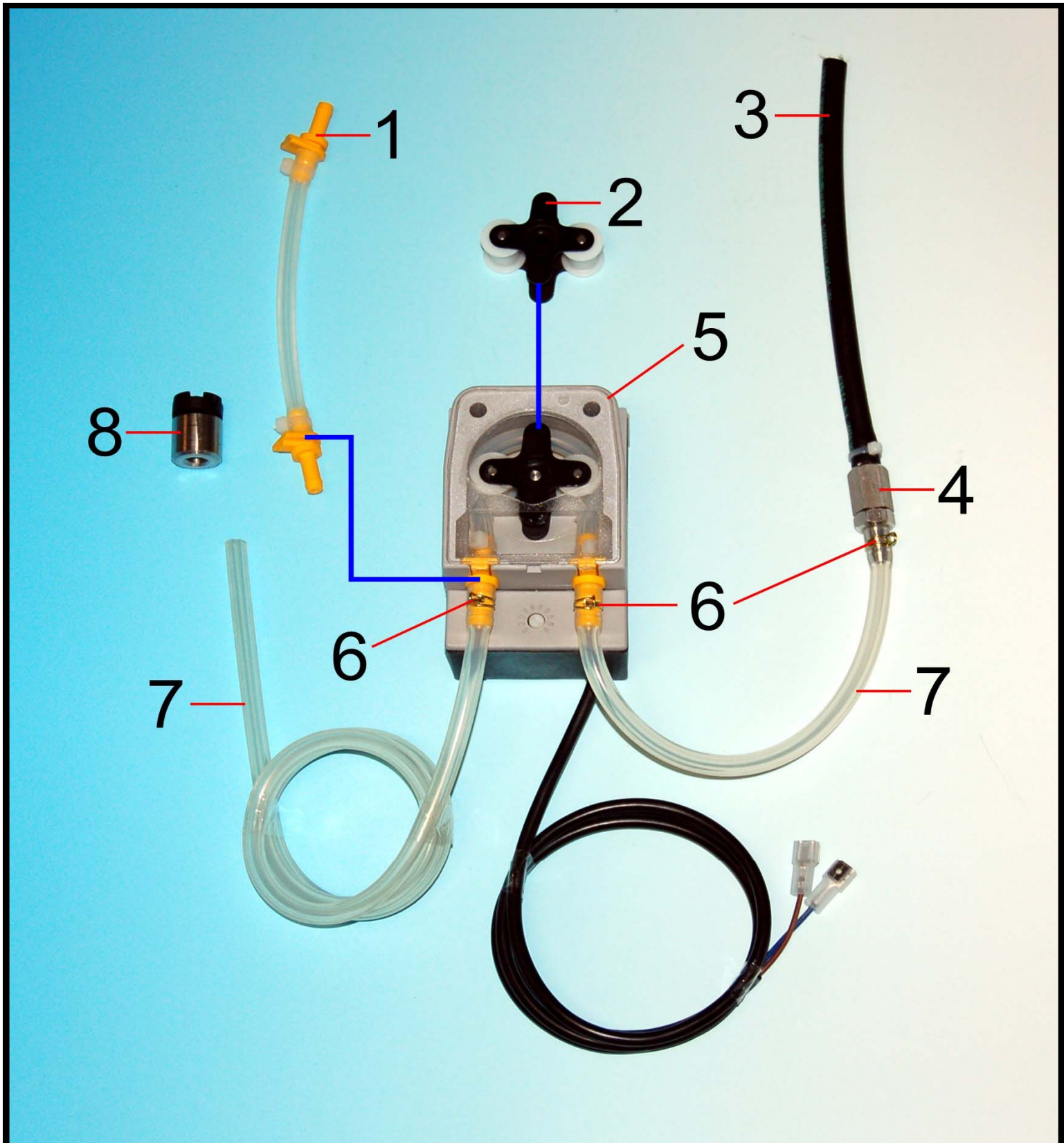

Pos.	Codice	Descrizione	Description	Description
1	D0STSILSKC	Tubo silicone brillantante+attacchi	Peristaltic rinse aid tube with fittings	Tube silicone doseur produit rinçage
2	D0SPRRSKC	Portarullini peristaltica seko	Rotating pump head, rinse aid	Rotor
3	TG510DS	Tubo dosatore 5x10	Rinse aid tube to boiler	Tube doseur 5x10
4	D0SVNRSKC	Valvola non ritorno seko	Non return valve	Clapet anti retour
5	D0SBRIETLE	Dosatore brillantante "eur"	Rinse-aid pump housing	Doseur produit rinçage "eur"
6	FAM710	Fascetta a molla	Wire clip for tube	Collier
7	TSIL48	Tubo silicone 4x8	Silicone rinse aid inlet tube	Tube silicone 4x8
8	D0SVFFSK	Valvola di fondo con filtro seko	Foot valve with filter	Clapet avec filtre seko

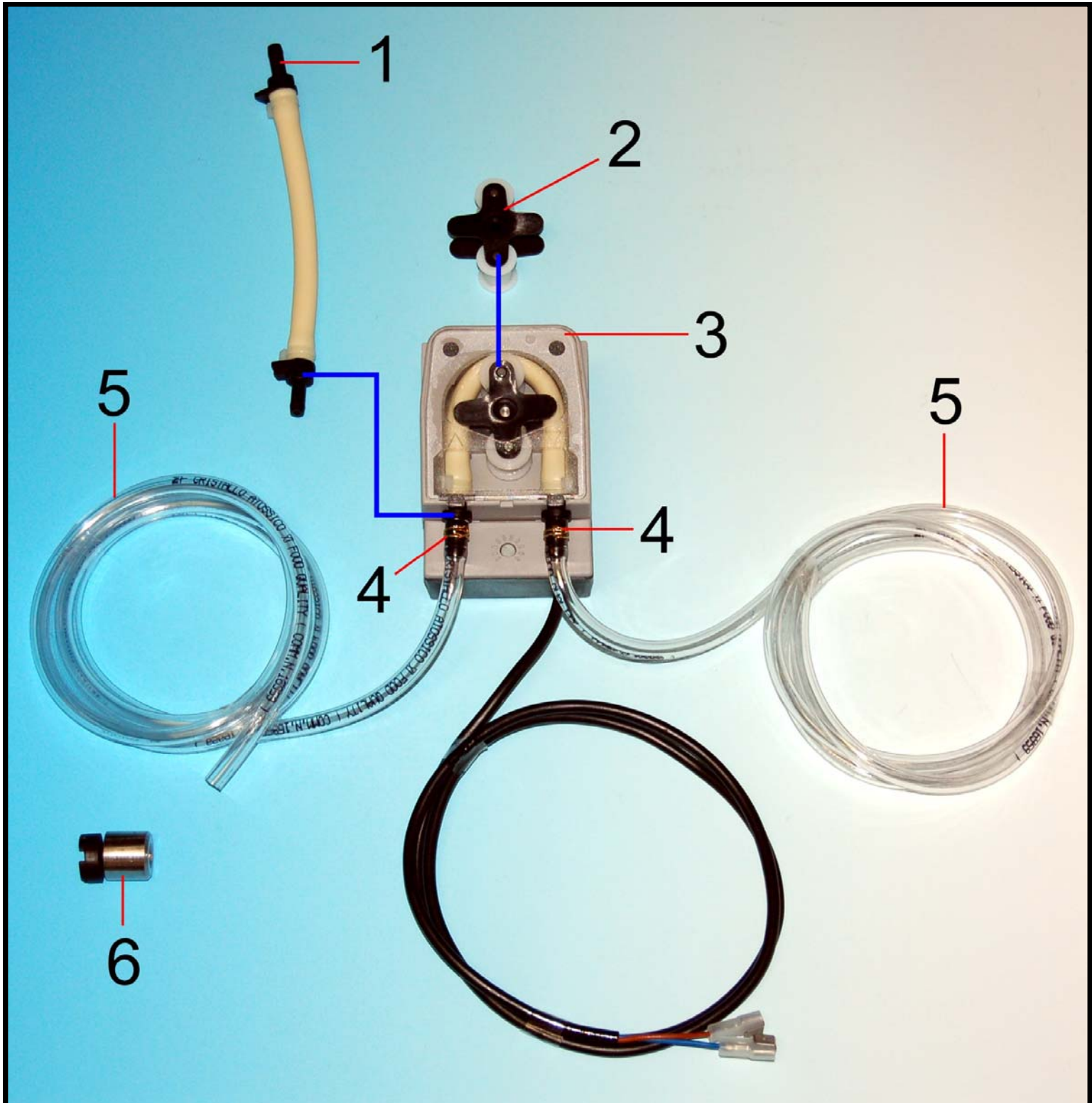

Pos.	Codice	Descrizione	Description	Description
1	D0STSANSKC	Tubo Santoprene detergente+attacchi	Peristaltic soap tube with fittings	Tube Santoprene doseur p. lavage
2	D0SPRRSKC	Portarullini peristaltica seko	Rotating pump head, soap	Rotor
3	D0SDETETLE	Dosatore detergente "eur"	Soap pump	Doseur produit de lavage "eur"
4	FAM710	Fascetta a molla	Spring clip for tubing	Collier
5	TC58	Tubo pvc cristal 5x8	Soap PVC tubing	Tube pvc cristal 5x8
6	D0SVFFSK	Valvola di fondo con filtro seko	Foot valve with filter	Clapet avec filtre seko

HANDLES

POIGNEES

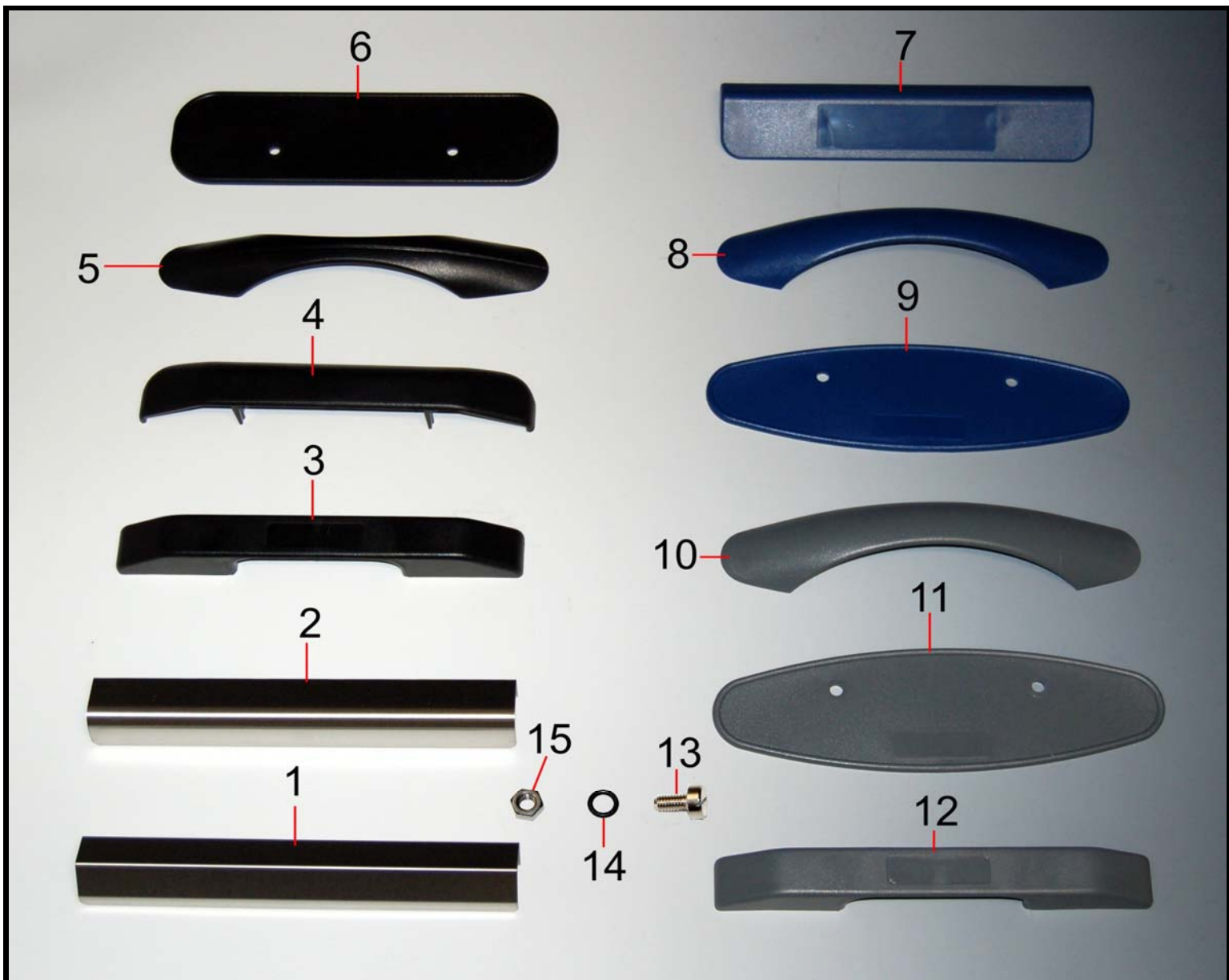

Pos.	Codice	Descrizione	Description	Description
1	AM010R	Maniglia poligonale inox	Handle, Stainless steel, angled section	Poignée porte inox inclinée
2	AM010F	Maniglia curva inox	Handle, Stainless steel, round section	Poignée porte courbe, inox
3	AM010PA	Maniglia aperta nera	Handle, black, thru grip, angled	Poignée porte noire
4	AM010PC	Maniglia chiusa nera	Handle, black, closed grip, curved	Poignée porte noire
5	AM010SW	Maniglia chiusa nera	Handle, black, thru grip, double curved	Poignée porte noire
6	AM010SMH	Cornice sottomaniglia nero	Handle backplate, rectangular	Entourage sous-poignée, noire
7	AM010SIM	Maniglia blu	Handle, blue, closed grip, rectangular	Poignée porte , bleue
8	AM010MD25	Maniglia chiusa ovale blu	Handle, blue, thru grip, oval	Poignée porte ovale, bleue
9	AM010CD25	Cornice sottomaniglia blu	Handle backplate, blue, oval	Entourage sous-poignée, bleue
10	AM010MD25GR	Maniglia chiusa ovale grigia	Handle, grey, thru grip, oval	Poignée porte grise
11	AM010CD25GR	Cornice sottomaniglia grigia	Handle backplate, grey, oval	Entourage sous-poignée, grise
12	AM010PAGR	Maniglia aperta grigia	Handle, grey, thru grip, angled	Poignée porte grise
13	VVSP6100	Vite maniglia	Screw, door handle fixing	Vis pour poignée porte
14	OR106	Or per vite maniglia	O-Ring, door handle screw	Joint torique pour poignée
15	VD6I	Dado M6	Nut, M6	Ecrou, M6

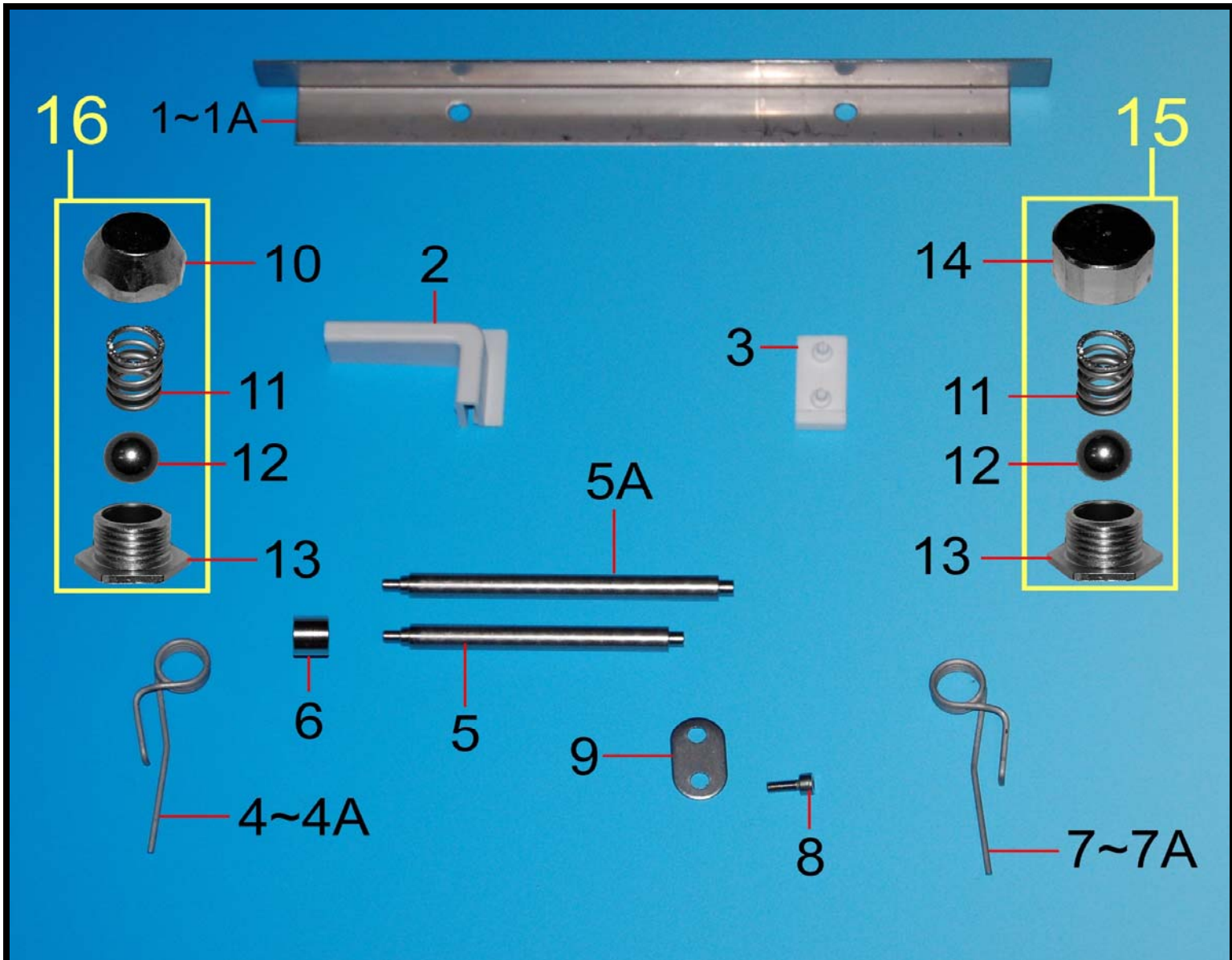

Pos.	Codice	Descrizione	Description	Description
1	GMDP1	Deflettore porta	Door deflector	Deflecteur porte
2	AM014B	Angolare vasca plastica	Plastic corner guard	Coin extérieure, plastique
3	AMPCP	Paracolpo porta	Door stop	Pare-chocs
4	AMMP1DX	Molla destra per porta	Door spring, RH	Ressort droit porte
4A	AMMP1A2DX	Molla destra per porta mod. alta	Door spring, RH	Ressort droit porte, porte haute
5	AM112NTM	Perno porta mod. 1	Door pin	Axe de la porte
5A	AM212NTM	Perno porta mod. 2	Door pin	Axe de la porte
6	AM012M	Distanziale	Door pin spacer	Entretoise
7	AMMP1SX	Molla sinistra per porta	Door spring, LH	Ressort gauche porte
7A	AMMP1A2SX	Molla sinistra per porta mod.alta	Door spring, LH	Ressort gauche porte, porte haute
8	VVEI410I	Vite, 4x10 mm	Screw, 4x10 mm	Vis, 4x10 mm
9	AM0PFPPM	Piastrina fissaggio perno porta	Pin security plate	Plaquette tenue pivot porte
10	AM011AR	Dado scrocchetto vasca raggiata	Ball catch nut, round corners tank	Bouchon de la bille, cuve rayonnée
11	AM011C	Molla scrocchetto	Ball catch spring	Ressort inox
12	AM011D	Sfera scrocchetto	Ball catch ball	Bille inox
13	AM011E	Sede sfera scrocchetto	Ball catch seat	Siège ressort inox
14	AM011A	Dado scrocchetto vasca quadra	Ball catch nut	Bouchon de la bille, cuve carrée
15	AM011	Scrocchetto completo vasca quadra	Door ball catch assy	Fermeture de porte, cuve carrée
16	AM011R	Scrocchetto completo vasca raggiata	Door ball catch assy, round corners	Fermeture de porte, cuve rayonnée

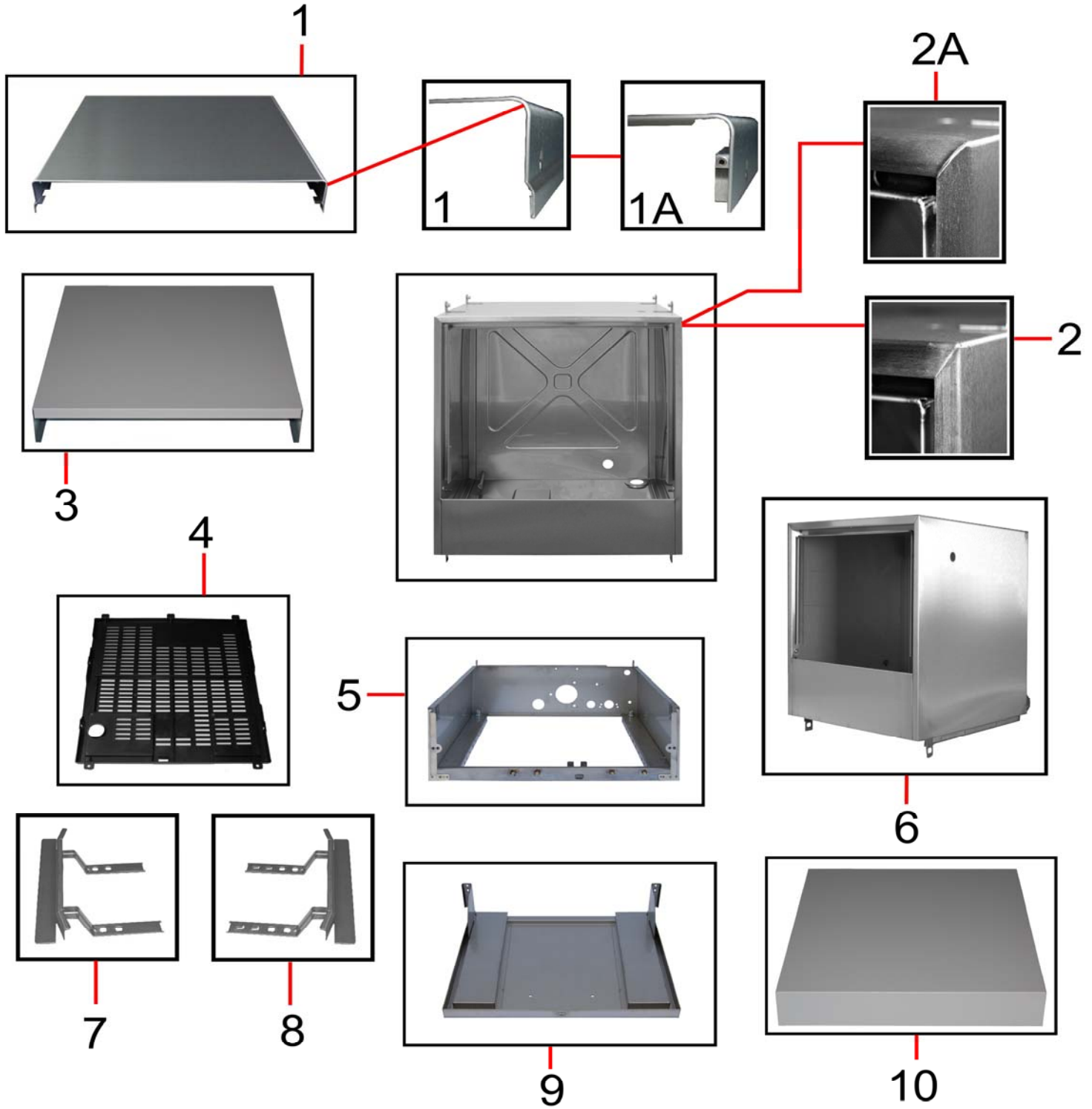

Pos.	Codice	Descrizione	Description	Description
1	GMPS1RDP	Pannello superiore	Top panel, steel	Panneau supérieur inox
1A	GMPS1N0S	Pannello superiore	Top panel, steel	Panneau supérieur inox
2	GMVA1CS	Vasca quadra	Wash cabinet, square corners	Cuve
2A	GMVA1R	Vasca raggiata	Wash cabinet, round corners	Cuve
3	GMPP1H65	Pannello posteriore	Back panel	Panneau dossieret
4	GMBAPR1PL	Protezione fondo basamento	Base protection screen	Protection panneau inferieur
5	G MBA1	Basamento	Base	Socle
6	GMVA1CL	Vasca comandi laterali	Wash cabinet,side control model	Cuve commandes laterals
7	GMGCSF1DSXI	Guida dx-sx supporto cestello senza filtri	Basket ramp, RH/LH without filters	Support panier gauche/droit sans filtres
8	GMGC1DSXI	Guida dx-sx supporto cestello con filtri	Basket ramp, RH/LH with filters	Support panier gauche/droit avec filtres
9	GMP01M	Porta	Door	Porte
10	GMPP1CL	Pannello posteriore comandi laterali	Back panel, side control model	Panneau dossieret commandes laterals

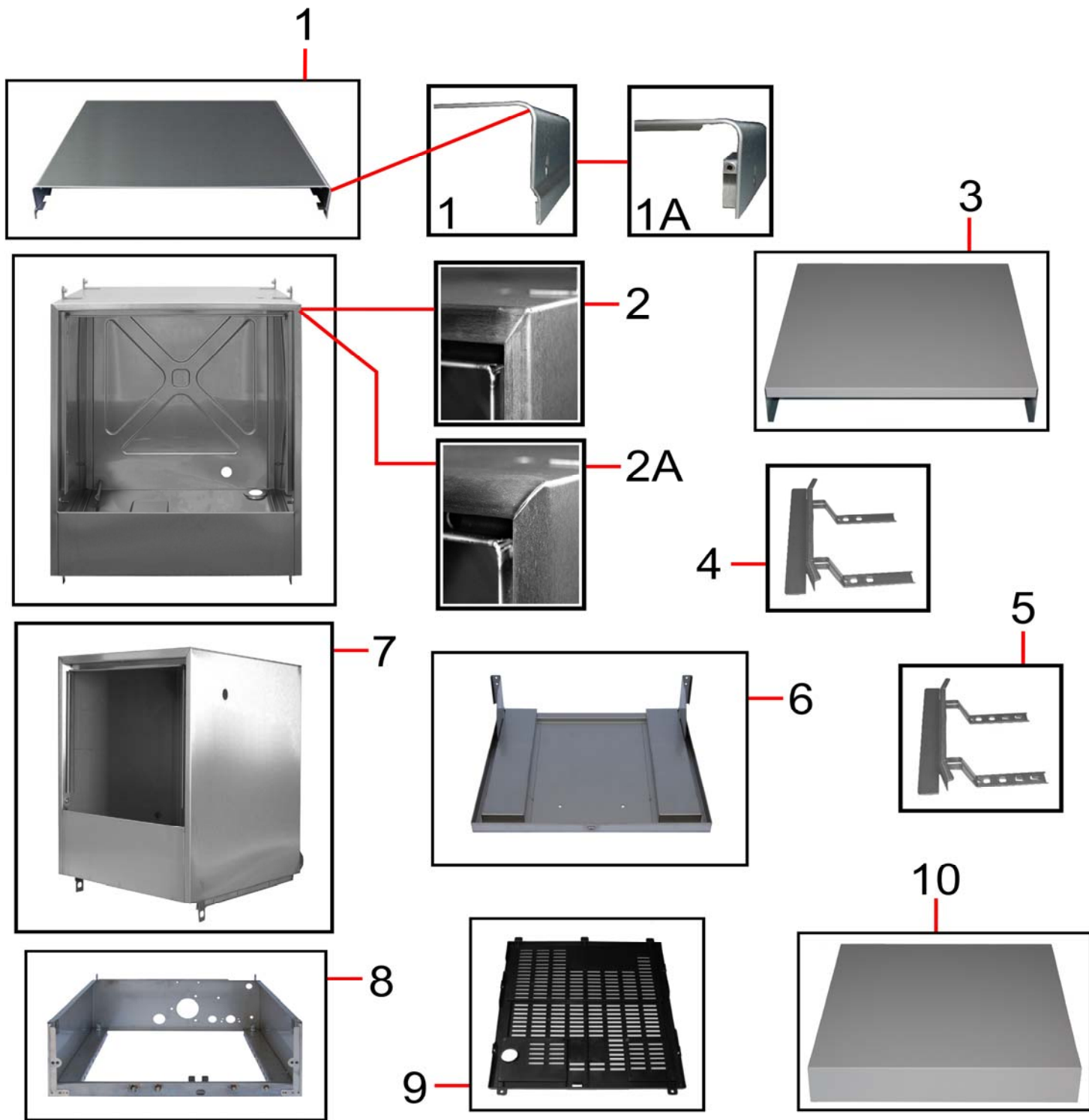

Pos.	Codice	Descrizione	Description	Description
1	GMPS1RDP	Pannello superiore	Top panel, steel	Panneau supérieur inox
1A	GMPS1N0S	Pannello superiore	Top panel, steel	Panneau supérieur inox
2	GMVA1ACS	Vasca quadra	Wash cabinet, square corners	Cuve
2A	GMVA1AR	Vasca raggiata	Wash cabinet, round corners	Cuve
3	GMPP1AH65	Pannello posteriore	Back panel	Panneau dossieret
4	GMGCSF1DSXI	Guida dx-sx supporto cestello senza filtri	Basket ramp, RH/LH without filters	Support panier gauche/droit sans filtres
5	GMGC1DSXI	Guida dx-sx supporto cestello con filtri	Basket ramp, RH/LH with filters	Support panier gauche/droit avec filtres
6	GMP01AM	Porta	Door	Porte
7	GMVA1ACL	Vasca comandi laterali	Wash cabinet , side control model	Cuve commandes lateral
8	GMBA1	Basamento	Base	Socle
9	GMBAPR1PL	Protezione fondo basamento	Base protection screen	Protection panneau inferieur
10	GMPP1ACL	Pannello posteriore comandi laterali	Back panel,side control model	Panneau dossieret commandes laterals

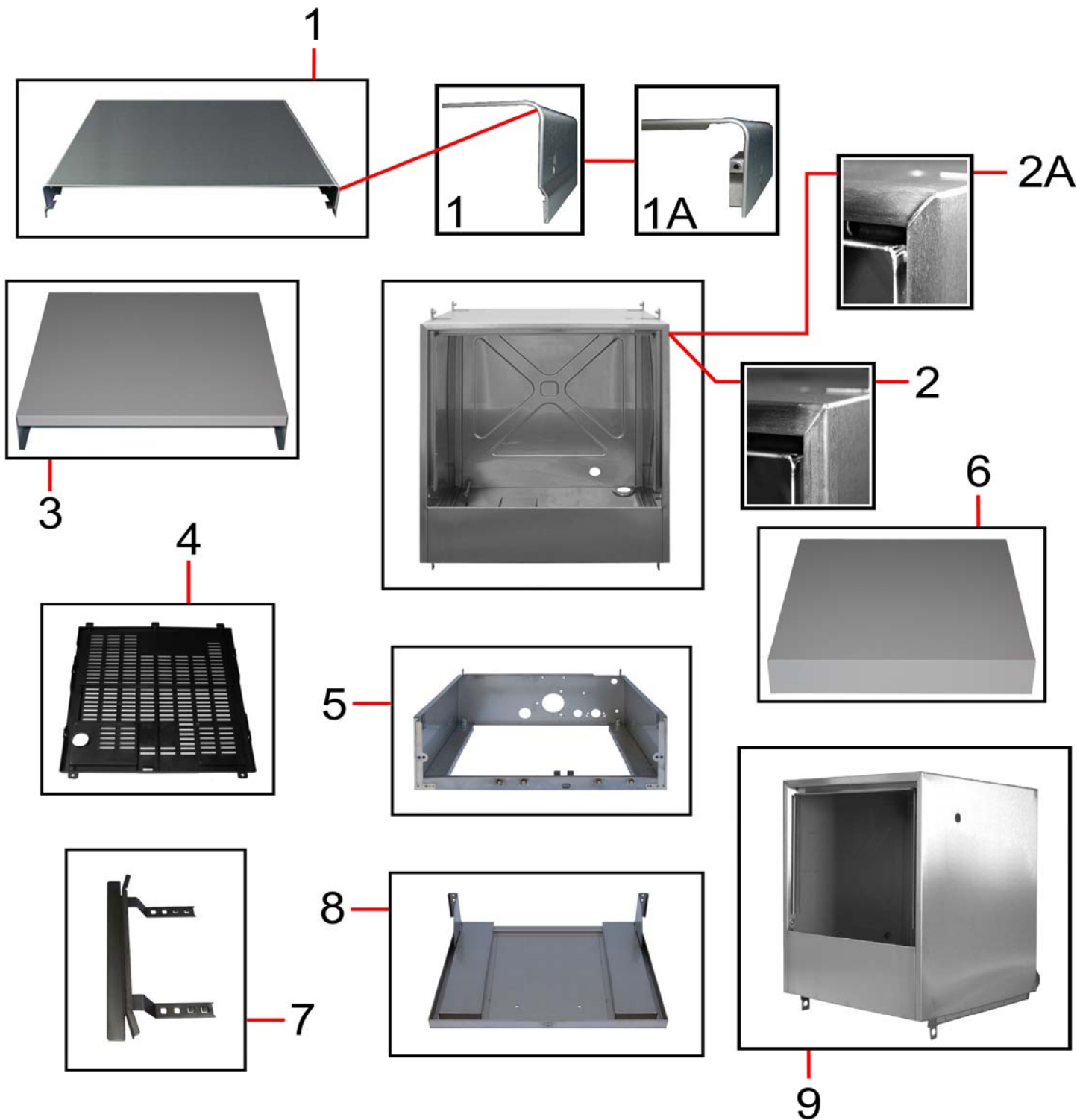

Pos.	Codice	Descrizione	Description	Description
1	GMPS2RDP	Pannello superiore	Top panel, steel	Panneau supérieur inox
1A	GMPS2N0S	Pannello superiore	Top panel, steel	Panneau supérieur inox
2	GMVA2APR5	Vasca quadra	Wash cabinet, square corners	Cuve carrée
2A	GMVA2ARPR5	Vasca raggiata	Wash cabinet, round corners	Cuve radiaire
3	GMPP2APR5	Pannello posteriore	Back panel	Panneau dossieret
4	GMBAPR2PL	Protezione fondo basamento	Base protection screen	Protection panneau inférieur
5	GMBAPR2PL	Basamento	Base	Socle
6	GMPP2ACL	Pannello posteriore comandi laterali	Back panel, side control model	Panneau dossieret commandes laterals
7	GMGC2DSXI	Guida supporto cestello	Basket ramp, RH/LH with filters	Support panier gauche/droit avec filtres
8	GMP02AMPR5	Porta	Door	Porte
9	GMVA2ACLPR5	Vasca comandi laterali	Wash cabinet, side control model	Cuve commandes lateral

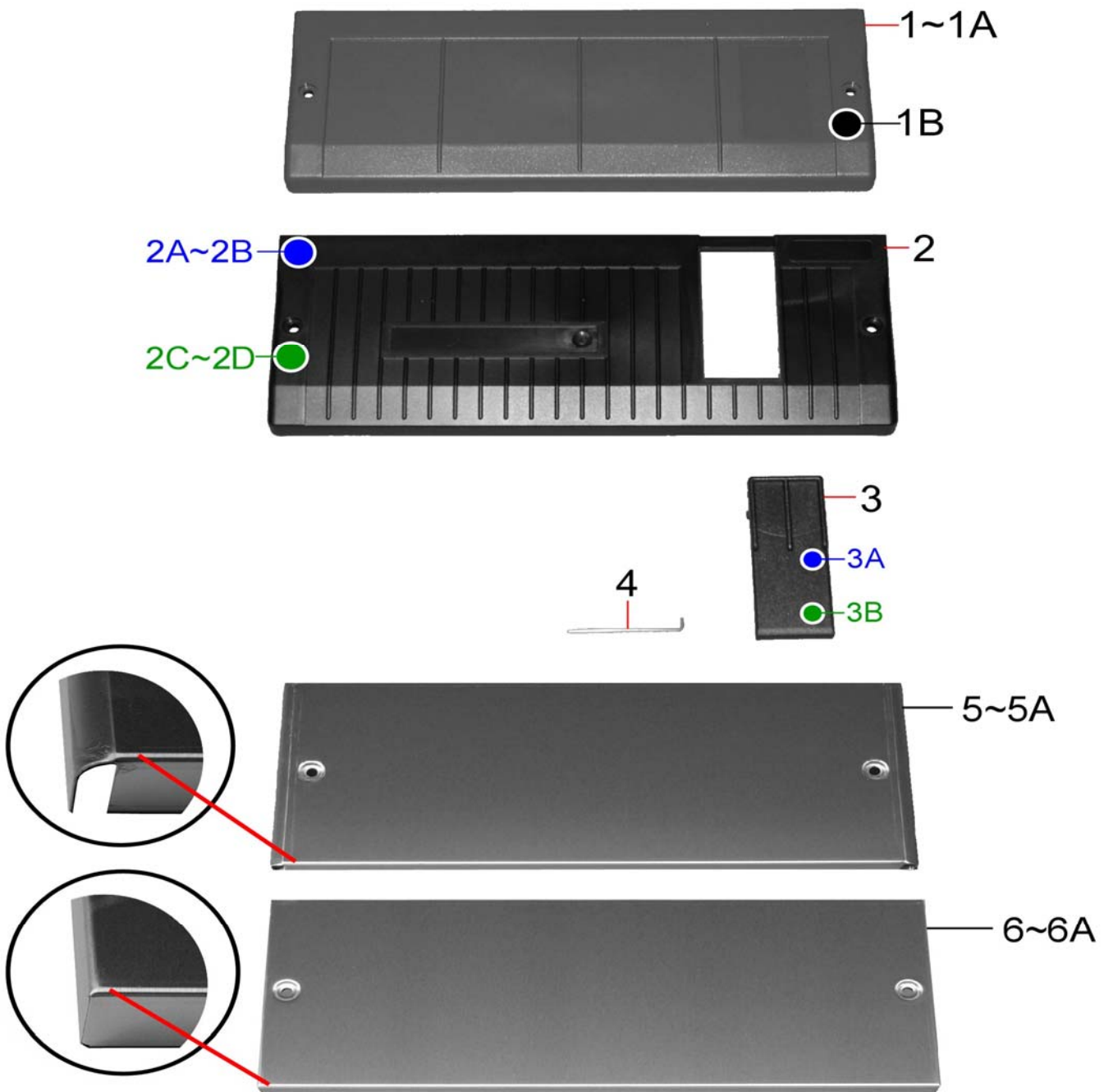

Pos.	Codice	Descrizione	Description	Description
1	GMCR1SCPLGR	Cruscotto grigio mod. 1 senza cava	Bottom panel, mod. 1, grey, plastic	Panneau socle inox, mod.1, gris
1A	GMCR2SCPLGR	Cruscotto grigio mod. 2 senza cava	Bottom panel, mod. 2, grey, plastic	Panneau socle inox, mod. 2, gris
1B	GMCR1SCPLNR	Cruscotto nero mod. 1 senza cava	Bottom panel, mod. 1, black, plastic	Panneau socle inox, mod. 1, noir
2	GMCR2CPL	Cruscotto nero mod. 2 con cava	Bottom panel, mod.2, black, plastic, aperture	Panneau socle plastique, mod. 2, noir
2A	GMCR1CPLBL	Cruscotto blu mod. 1 con cava	Bottom panel, mod.1, blue, plastic, aperture	Panneau socle inox, mod. 1, bleu
2B	GMCR2CPLBL	Cruscotto blu mod. 2 con cava	Bottom panel, blue, mod.2, plastic, aperture	Panneau socle inox, mod. 2, bleu
2C	GMCR1CPLV	Cruscotto verde mod. 1 con cava	Bottom panel, mod. 1, green, plastic, aperture	Panneau socle inox, mod. 1, vert
2D	GMCR2CPLV	Cruscotto verde mod. 2 con cava	Bottom panel, mod. 2, green, plastic, aperture	Panneau socle inox, mod. 2, vert
3	AM0TCBPL	Tappo cava nero	Plastic cover for r/a opening, black	Bouchon, noir
3A	AM0TCBPLB	Tappo cava blu	Plastic cover for r/a opening, blue	Bouchon, bleu
3B	AM0TCBPLV	Tappo cava verde	Plastic cover for r/a opening, green	Bouchon, vert
4	AM029	Spina fissaggio inox	Securing rod for r/a reservoir	Bonde fixation inox
5	GMCR1SCR	Cruscotto inox senza cava mod. 1	Bottom panel, steel, mod. 1	Panneau socle inox, mod. 1
5A	GMCR2SCR	Cruscotto inox senza cava mod. 2	Bottom panel, steel, mod. 2	Panneau socle inox, mod. 2
6	GMCR1SC	Cruscotto inox senza cava mod. 1	Bottom panel, steel, mod. 1	Panneau socle inox, mod. 1
6A	GMCR2SC	Cruscotto inox senza cava mod. 2	Bottom panel, steel, mod. 2	Panneau socle inox, mod. 2

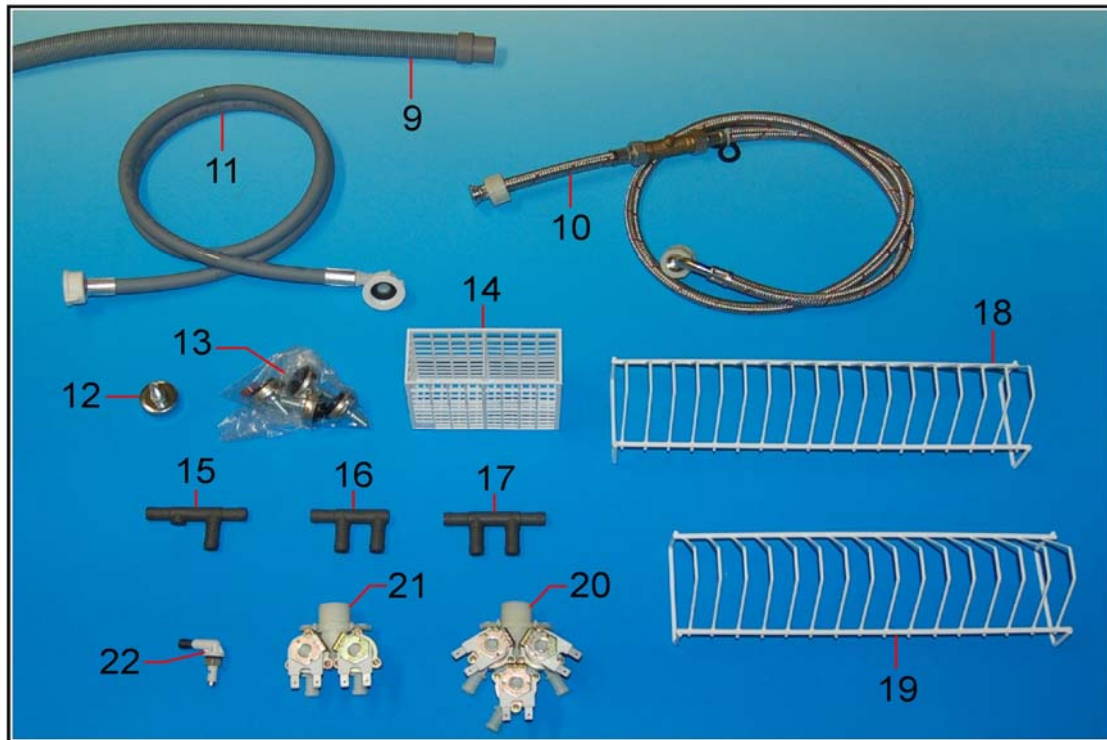
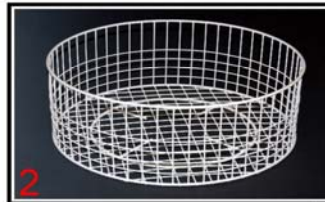
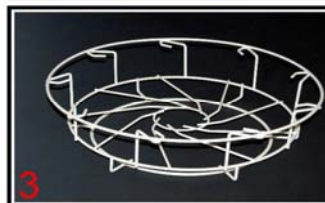
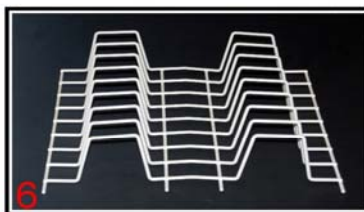

Pos.	Codice	Descrizione	Description	Description
1	CT3617PL2	Cestello Ø 36x17	Round basket plastic Diam 36x17	Panier, diam 36x17
2	CT4117L	Cestello Ø 41x17	Round basket wire, diam 41x17	Panier, diam 41x17
3	CT419P	Cestello Ø 41- 9 piatti	Round rack wire , diam 41 - 9 plates	Panier , diam 41- 9 assiettes
4	CQ3516LPL	Cestello 35x35x16	Glass basket 35cm square plastic	Panier 35x35x16
5	CQ4016LPL	Cestello 40x40x16	Glass basket 40cm square plastic	Panier 40x40x16
6	CQIP408P	Inserto piatti 8 posti 40x40	Dish insert 400 square 8 plates	Support 8 assiettes 40x40
7	CQ4025B	Cestello 40x40x18 con inserto bicchieri	Rack assy tall glasses 40x18	Panier 40x40 avec support verres
8	CQIB403F	Inserto bicchieri 3 file 40x40	Rack base tall glasses 40x40	Support verres 40x40
9	GS130	Tubo scarico Ø 25	Drain Pipe Diam 25	Tuyau de vidange, diam 25
10	VDCVGB	Doppia valvola con tubo carico	DbI Chk Valve & hose, WRC	Double valve avec tuyau entrée eau
11	TC3415	Tubo carico "vde" mt. 1,5	Water Supply Hose, 3/4" BSP, 1,5 m	Tuyau entrée eau "vde" mt. 1,5
12	AM016NT	Piedino regolabile lavabicchieri	Adjustable foot - glasswashers	Pied réglable - lave verres
13	AM016NTC	Confezione 4 piedini lavabicchieri	Set of 4 adjustable feet - glasswashers	Set nr.4 pieds - laveverres
14	IP2PP	Inserto porta posate piccolo	Small cutlery basket	Godet porte couverts petit
15	GB017	Portagomma a "T" 1 via	Tee Connector	Raccord à "T" 1 voie
16	GB017NT	Portagomma a "L" 1 via	3 Way Connector	Raccord à "L" 1 voie
17	GB055	Portagomma a "T" 2 vie	Double Tee Connector	Raccord à "T" 2 voies
18	CTIP17	Inserto porta piattini 17 posti	Large saucer rack	Godet porte soucoupes petit (17 assiettes)
19	CTIP15	Inserto porta piattini 15 posti	Small saucer rack	Godet porte soucoupes (15 assiettes)
20	CEEV3	Elettrovalvola 3 vie 220 volt	Solenoid Valve, 3-Way, 220V	Electrovanne 3 voies 220 volt
21	CEEV2	Elettrovalvola 2 vie 220 volt	Solenoid Valve, 2-Way, 220V	Electrovanne 2 voies 220 volt
22	DSDET040BC	Iniettore completo	Soap Elbow Assy	Injecteur completo

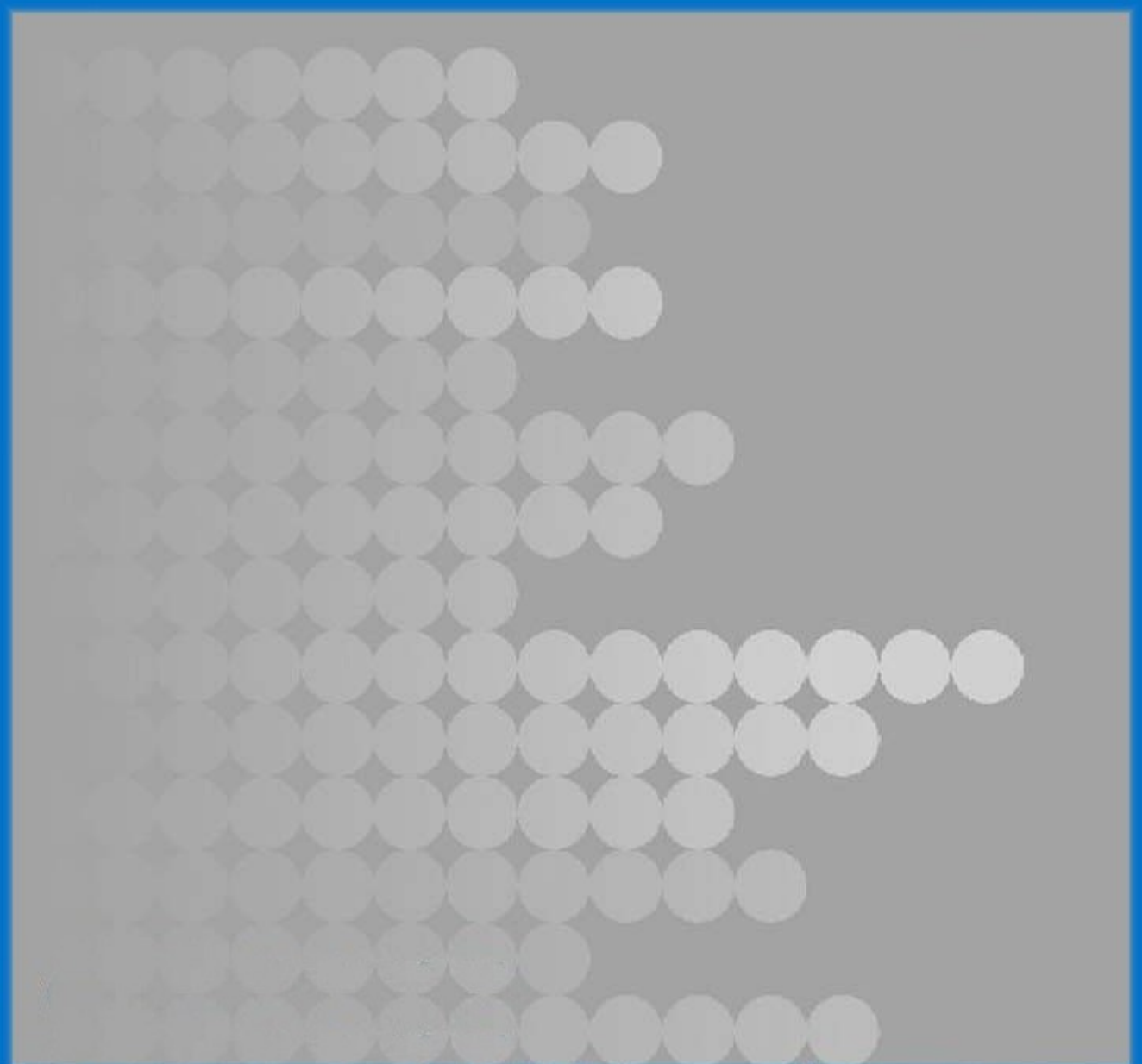

1007/105.00

